



## **MAINTENANCE INSTRUCTION FOR Superlight SL-3**

### **1.1 General instruction**

#### **WARNINGS**

- 1. During maintenance operation on SL-3**  
**Mechanical systems - (i.e., motor and wheel) - disconnect the connectors from the batteries to avoid casual operation.**
- 2. During each electrical test, lift the one rear wheel by means of block and avoid touching moving parts.**
- 3. All technical operations for the SL-3 should be done only by trained and authorized technician.**

**The following are instructions for the technician receiving the SL-3 for normal service or for repair.**

- 1. During the SL-3 service, the vehicle should be parked on a level surface, with the key switch disengaged.**
- 2. Prior to the beginning of work, check the vehicle for initial troubleshooting.**
- 3. When the SL-3 is entering for repair, troubleshooting the vehicle using in chapter 1.3 .**
- 4. When the SL-3 is entering for general check or preventive maintenance, review this maintenance instruction for supporting information.**

### **1.2 List of specific tools**

- a. Standard technician tool box (wrenches, screw drivers, hexagon socket screws key set, etc.).**
- b. Multimeter (Voltmeter) and Amphometer.**
- c. Steel band for wires inserting**
- d. Terminals extractor**

#### **NO load test and driving test**

**This test is very much recommended when there is a suspicion of Transaxle-Power-Unit parts faults , or when irregular noises are coming from the Power-Unit . Also when there are complains about too short travel distance, or battery faults.**

**For these Tests Connect a DC current meter on the Battery Red Positive (+) Power wire. It is recommended to use an induction current meter (So that no physical connection is needed) . Make sure the meter wires are far away from any moving parts. The meter Range needed is up to 40 Amperes .**

**For No load test use appropriate wood blocks lift the one or two rear wheels of the SL-3 up, so that they are free to turn without touching the floor . Squeeze the speed lever to maximum and run the breeze for 1-2 minutes before measuring . Than measure the current consumption should be between 2.5A to 3A .**

**For Drive test load drive the SL-3 at full speed on level surface with a user weight of 70-80 Kg (154-176 lbs) . Than measure the current consumption should be between 6A to 7A .**

### 1.3 Mechanical troubleshooting

You have attached full set of drawings include full instruction how to assemble and order every part of the SL-3

(every drawing will be open by touch as PDF file)

More drawings can be find in the CD

SL-3 assembly for service	- <a href="#">FTSL999</a>
Frame assembly	- <a href="#">ASSL003</a>
Tiller assembly	- <a href="#">ASSL005</a>
Gear-motor-e.m.b assy.	- <a href="#">ASSL021</a> + <a href="#">ASSL001</a>
Speed control assembly	- <a href="#">ASSL011</a>
Seat fold assembly	- <a href="#">ASSL030</a>
Battery right 18A assembly	- <a href="#">ASSL015</a>
Battery Left 18A assembly	- <a href="#">ASSL016</a>
Elec. house assembly	- <a href="#">ASSL008</a>
Cover electronic assy.	- <a href="#">ASSL014</a>
Speed control assy.	- <a href="#">ASSL011</a>
Front wheel assy.	- <a href="#">ASSL007</a>
Rear wheel pneumatic assy.	- <a href="#">ASSL018</a>
Cover power unit assy.	- <a href="#">ASSL017</a>

This paragraph discusses the SL-3 mechanical troubleshooting and repair procedures

No.	Symptom	Probable Cause	Remedy
1	Excessive tolerance of the rear wheel.	- Excessive wear of the rear wheel or broken.	- Replace the rear wheel <a href="#">ASSL021</a> refer to drawing
2	When squeezing Operating Lever (either left or right) and releasing it, the Lever does not return to the neutral position.	- The Lever (internal) - Spring is broken or displaced.  The adjustment of poten. Is out of order	- Replace broken spring or damaged assembly, refer to <a href="#">ASSL011</a> drawing.  Adjust the potentiometer
3	Excessive noise from the gear.	- Broken gear, excessive wear of gear wheel and bearing damage.	- Replace motor, gear or e.m.b refer to drawing <a href="#">ASSL021</a> and drawing <a href="#">ASSL001</a>
4	No power	Main harness damaged  The connectors on the tiller or on the battery damage	Replace the main harness Refer to drawing <a href="#">ASSL003</a> Replace the connector see drawings <a href="#">ASSL005</a> <a href="#">ASSL015</a> <a href="#">ASSL017</a>
5	Head light doesn't operate	Light bulb	Open the rear motor cove Replace the bulb, see drawing <a href="#">ASSL014</a>
6	The tiller is too free or too stiff	The adjustment of the shaft bearing not good	Adjust the bearing nut See drawing <a href="#">ASSL006</a>
7		Battery	Replace battery See drawing <a href="#">ASSL015</a> + <a href="#">ASSL016</a> (for 18A) <a href="#">ASSL024</a> + <a href="#">ASSL025</a> (for 26A)

## **1.4 Electrical troubleshooting**

### **CONTENTS**

1. **PANEL DISPLAY**
  - 1.1 **Battery Gauge Display**
  - 1.2 **Status LED indicator**
2. **HEADLIGHT**
3. **HORN**
4. **LOW / HIGH SPEED CONTROL**
5. **CHARGING**
6. **PARKING BRAKE ASSEMBLY**
7. **THE MOTOR HARNESS**
8. **THE THROTTLE POTENTIOMETER**
9. **OPERATIONAL TESTS**
  - 9.1. **Performing operational test using the handheld programmer**
10. **DIAGNOSTICS**
  - 10.1 **Diagnosing and troubleshooting using programmer diagnostics mode**
11. **PROGRAMMING**
12. **REPLACEABLE PARTS LIST**
13. **ATTACHMENT :**
  - a. **parameters listing**
  - b. **Electric diagram SL-3.**
  - c. **Control and display boards.**

# 1. PANEL DISPLAY

## 1.1 Battery Gauge Display

The Panel Display comprises an accurate Battery Gauge Display and a Status indicator. When the key switch is turned on the Battery Gauge displays the remaining capacity of the batteries and the Status led provides diagnostics information.

### 1.1 Battery Gauge Display

By using four led bars the Battery Gauge Display indicates how much charge is left in the scooter's batteries.

Fig1. Panel Display

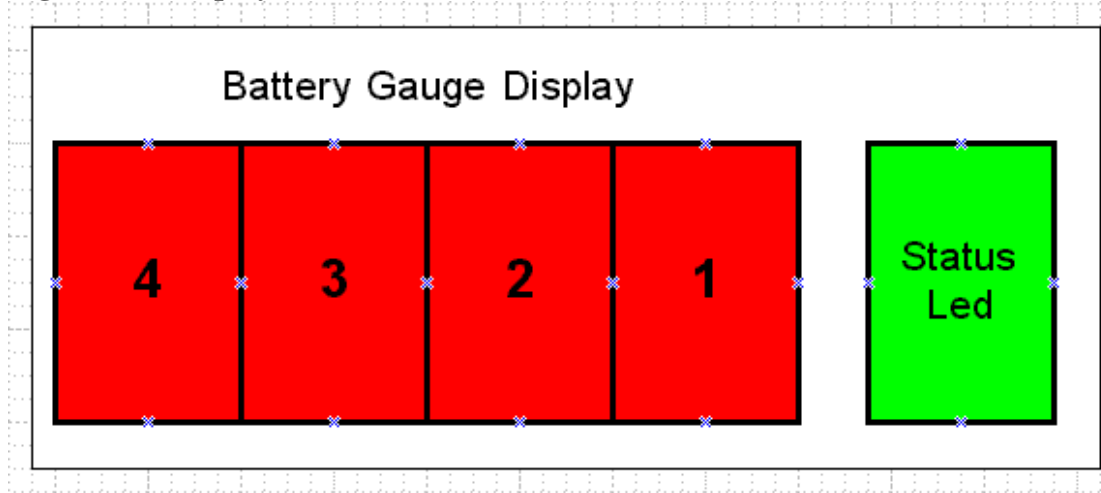



Table 1











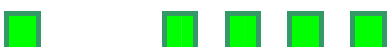

LED 4	LED 3	LED 2	LED1	Battery Remaining Capacity % (BRC)	
ON	ON	ON	ON	80% < BRC < 100%	
OFF	ON	ON	ON	60% < BRC < 80%	
OFF	OFF	ON	ON	40% < BRC < 60%	
OFF	OFF	OFF	ON	20% < BRC < 40%	
OFF	OFF	OFF	Flashes	BRC% < 20%	
OFF	OFF	OFF	Flashes	POWER SAVE MODE	
<p>If the throttle remains in neutral beyond 20 minutes the controller powers down. The led 1 flashes and the Status led is turned off. (parameter "Sleep Dly" is 20)            Normal operation resumes when the key switch is turn off-turn on.            If the flash not stop – charge the battery for 10 minutes, or change the parameter Sleep Dly to "o"            The new model (serial no. after 01800) the parameter "Sleep Dly" is adjust to "o"</p>					
OFF	OFF	OFF	OFF	CHARGING MODE	
<p>During charging the Battery Gauge Display and the Status indicator go off. The drive is inhibited too.</p>					

<b>FAULTS TROUBLESHOOTING</b>				
<b>OFF</b>	<b>OFF</b>	<b>OFF</b>	<b>Flashes</b>	 <p><b>FAULT</b></p> <p>1.Open wire fault –replace the cable that connect the controller with the Front board</p> <p>2. Inaccurate gauge meter operation- replace the controller</p> <p>3. Inaccurate battery gauge display operation - replace the Front Board</p> <p>4. Incorrect charging – replace the charger</p> <p>5. The batteries were charged not through the scooter charging circuitry. Connect the batteries to the scooter electrical harness and plug in the charger. Wait at least 10 minutes. Unplug the charger and turn on the key switch if necessary. You should see the full capacity indication.</p>
<b>OFF</b>	<b>OFF</b>	<b>OFF</b>	<b>OFF</b>	 <p><b>FAULT</b></p> <p>1.Check if the batteries are connected and the circuit breakers were reset. If the circuit breaker is defective the voltage will not pass through to the front end of the scooter. Take a voltage reading at each individual battery.</p> <p>2.Check if the power cord is plugged into the tiller receptacle.</p> <p>3.Check the power harnesses that run along the chassis. Unplug the front to rear power cord. Take a volt reading across the two outside pins on the power plug that must connect to the tiller. You should read the total battery voltage.</p> <p>4.Check the connections between Front board and Charging board adapter (T1, T2, T3).</p> <p>5.Check the connections at B+ and B- Controller’s terminals</p> <p>6. F1 tripped. Replace the Front board or check and replace the fuse F1.</p> <p>7. Check the key switch and the battery voltage path the battery voltage. The battery voltage that is sent to the Front board is returned back to Front board and controller.</p>

## 1.2 STATUS LED INDICATOR

The diagnostics information can be obtained observing the fault codes issued by the Status LED. First it displays a fast flash for 10 seconds then flashes a 2-digit fault identification code.

Table 2

A TWO DIGITS CODE	B LED CODE	C FAULT
(1, 1)		Controller thermal cutback Overheating can occur if the controller is overloaded or the electromagnetic brake is not releasing properly. The main current limit decreases steadily until it is reduced to zero. At the reduced performance level the vehicle must be parked. Full current limit and performance return automatically after the controller cools down.
(1, 2)		Throttle fault The throttle potentiometer is connected at the Front board by blue, green and brown wires 1.check for open and short circuits pins 2.defective throttle potentiometer 3.loose connection
(1,3)		Controller or wiring fault 1. The cable connecting the Controller with the Front board has interrupt the wire between 18-18 2. Defective Front board 3. Defective Controller
(1, 4)		Low battery voltage The voltage batteries decreases at 17V limit and less than this limit. The drive is allowed.
(3, 1)		HPD fault Improper sequence of throttle and the Key Switch or throttle out of calibration. The high –pedal-disable (HPD) feature prevents controller outputs if the controller is turned on when the throttle is not in neutral. After 10 seconds of a continuous HPD fault driving is inhibited until power to the controller is cycled
(3,2)		Electromagnetic brake fault
(3, 4)		Electromagnetic brake fault Check for a short circuit between wires of the brake coil or for open wires. The drive is inhibited. Replace the electromagnetic brake assembly.
(3,3)		Controller failure or low battery voltage Check the voltage across the batteries (the total voltage battery) If the voltage is greater than 21V then replace the controller otherwise proceed with charging.
(4, 4)		Short in motor or in motor wiring or Controller failure
(4,2)		Motor fault or controller fault or the motor voltage does not match the throttle request
(2, 1)		Controller internal fault
(2, 2)		Controller internal fault
(4, 1)		Motor fault or Controller fault

## **2. HEADLIGHT**

**During charging the Headlight is not operable.**

<b>The headlight doesn't operate</b>	<b>Check and replace if necessary the headlight beam lamp</b>
	<b>Check the fuse F2 The fuse F2 is mounted on the Front board Take a volt reading from each side of the fuse to GND. As GND connection use T3. If either of the readings is zero volts replace the Rear board. If one of readings equals the voltage battery and the second indicates zero volts replace the fuse F2. F2 is specified as: Slow Blow type fuse 1A / 250V P/N:218.001 or P/N: 215.001 LITTELFUSE</b>
	<b>Check the connections between the Light switch and the Front board Replace the Light switch.</b>
	<b>Check wire-to-wire connection between the Headlight assembly and the Front board.</b>
<b>The lights can be operated during charging</b>	<b>Front Board faulty</b>

## **3. HORN**

<b>Horn does not operate when the pushbutton is depressed</b>	<b>Check for reverse wiring connection</b>
	<b>Check the push button connection</b>
	<b>Push button faulty</b>
<b>Horn doesn't operate when driving reverse direction</b>	<b>Connect the jumper between header's terminal 2 and 3. The JP1 header is mounted on the Front board.</b>
<b>Horn does not operate when the brake is manually released</b>	<b>Check and repair when necessary the micro-switch wires continuity When manually release the brake check if the micro-switch will close its contacts. If not replace the brake assembly. Replace the Front board. Check the horn connections and reverse if necessary. Replace the horn.</b>
<b>Horn does not beep on fault condition</b>	<b>Move the jumper between terminals 2 and 3 of the header JP1. Use the handheld programmer and change the value of parameter "FAULT BEEP" from OFF to ON.</b>

## 4. LOW / HIGH SPEED CONTROL

The switch selects the driving mode (maximum speed limited at 60% or no limit)

High speed mode = the switch's contacts are closed and the lamp illuminates

Low speed mode = The switch's contacts are opened and the lamp is turned off.

<p>The scooter does not travel at full speed and the battery condition is good</p>	<p>1. Check connections of the switch with the Front board. The connections must fit the following table:</p> <table border="1" data-bbox="772 472 1487 584"> <tr> <td>Switch 1A</td> <td>Black</td> <td>Six circuits plug pin- 6</td> </tr> <tr> <td>Switch 1</td> <td>White</td> <td>Six circuits plug pin-5</td> </tr> <tr> <td>Switch 1B</td> <td>Red</td> <td>Six circuits plug pin-4</td> </tr> </table> <p>2. Check cable that connect the Controller with the Front board; check the continuity of wire that runs between 8-8 each connector.</p> <p>4. Replace the Front board</p> <p>5. Replace the Controller</p>	Switch 1A	Black	Six circuits plug pin- 6	Switch 1	White	Six circuits plug pin-5	Switch 1B	Red	Six circuits plug pin-4
Switch 1A	Black	Six circuits plug pin- 6								
Switch 1	White	Six circuits plug pin-5								
Switch 1B	Red	Six circuits plug pin-4								
<p>Turning the switch into Fast position blows the fuse F1 located on the Front board</p>	<p>Red wire is reversed with White wire</p>									
<p>The switch is working in reverse way</p>	<p>Red wire is reversed with Black wire</p>									
<p>Indifferent how the switch is set the lamp glows continuously</p>	<p>Black wire is reversed with White wire</p>									

## 5. CHARGING

Indifferent which position is selected for Key Switch the system automatically will detect if the charger outlet is plugged into the vehicle's charging socket and the panel display is shut off.

The drive and lights functions are not allowed.

The charging current is routed via the controller, scooter's power cord, the sixteen wires cable, Front board and the Charging board adapter. The charging circuit is protected by a manually resettable 4Amp circuit breaker. The charging average time may be about 10 hours.

<p>AC power is plugged in and the charger DC outlet is connected to the scooter's socket but the charger's display flashes informing the battery side is not connected</p>	<p>1. Check circuit breaker status. Take a volt reading from one of the metal tabs on the bottom of the circuit breaker to the most negative battery terminal (GND). If either of the readings is different than the total battery voltage reset or replace the fuse.</p> <p>2. Check the connections between Charging Adapter board and Front board</p> <table border="1" data-bbox="812 1733 1487 1845"> <tr> <td>T1</td> <td>RED</td> <td>T1</td> </tr> <tr> <td>T2</td> <td>BLUE</td> <td>T2</td> </tr> <tr> <td>T3</td> <td>BLACK</td> <td>T3</td> </tr> </table> <p>3. Charging socket damaged. Replace the Charging Adapter board</p>	T1	RED	T1	T2	BLUE	T2	T3	BLACK	T3
T1	RED	T1								
T2	BLUE	T2								
T3	BLACK	T3								

	4.Faulty charger
	5.Check the batteries connections and status of each circuit breaker included in the battery pack .
After full charging the Battery Gauge Display indicates battery capacity different than 100%	1.Incorrect charging. The charger was left connected less time than necessary. The user must wait the green indication of the charger's display
	2. Charger is not operating properly
	3. The batteries were charged in other place not mounted to the vehicle
	4. Defective controller
	5. Defective Front board
	6. Defective Display module
If the battery gauge reading seems to fall more quickly than usual or the travel distance between two consecutive charging decreases more quickly than usual proceed as follows:	1. Replace batteries
	2. Replace charger
	3.Potential mechanical problem. Check the gear –motor and the electromagnetic brake

## **6. PARKING BRAKE ASSEMBLY**

A micro-switch is attached to the parking brake so that when the brake is manually released the system is inhibited and will not drive

How is tested the electric continuity of the brake coil?	Switch off the power. Unplug the 4-pin connector with two black and two white wires from the header J3 located on Front board. Turn your meter to ohms or resistance scale. Take a resistance reading from black to black. A reading of approximately 65 ohms should appear.
How to check if the micro-switch is working properly?	While motor cap knob set in normal position take a resistance reading from white to white wire. The micro-switch should be open. Turn clockwise the motor cap knob. The micro-switch is closed and the meter reads 0 ohms.
How is tested the brake voltage output?	Turn on the scooter. Ensure the brake assembly connector is plugged into J3 header located on the Front board. Take a volt reading across the brake coil by pushing the red probe into the terminal 1 of the connector J3 and black probe into the terminal 2 of the same connector. The voltage brake should jump to the total battery voltage as soon as the throttle is depressed in either direction. The brake assembly is always locked until voltage is applied to it. When voltage is applied to the brake coil a magnetic field is generated. The magnetic field pulls away a plate that locks the brake into place and allows the motor to spin freely. You must be able to hear the parking brake operate within a few seconds.

<p><b>No drive and the Status indicator flashes (3, 2) code</b></p>	<p><b>1.Check if brake connector is plugged into J3 header. Switch power off and perform the brake coil continuity test. If the reading does not appear correctly check for open or shorted wires. If they are good replace the brake assembly.</b>  <b>2.Switch the power on and perform the voltage brake output test. If the reading does not appear correctly one of the following parts could be faulty:</b></p> <ul style="list-style-type: none"> <li>- Cable that connects the controller with the Front board</li> <li>- Controller</li> <li>- Front board</li> </ul>
<p><b>Excessive heat on the brake body</b></p>	<p><b>The brake assembly is mechanically damaged. Replace the brake assembly</b></p>
<p><b>When turn the cap motor knob to release brake the horn doesn't sound and the driving is not inhibited</b></p>	<p><b>Perform the micro-switch test If the micro-switch operates properly replace in the following order: Front board, cable between Front and Controller board and final the Controller.</b></p>

## **7. THE MOTOR HARNESS**

<p><b>How to check the controller output?</b></p>	<p><b>Measure the voltage between controller's terminals M1 and M2.</b>  <b>When is selected Forward direction M1 will be more positive than M2 and the voltage read is approximately 1.5V less than the total battery voltage. With the throttle bar fully depressed in Reverse you should see a negative reading of about 60% of the total battery voltage.</b></p>
<p><b>How to connect the gear-motor?</b></p>	<p><b>Connect Yellow cable to M2 controller's controller terminal and Brown cable to M1</b></p>
<p><b>The controller output appears to be normal but the performances are lowered or the motor doesn't run any more.</b></p>	<p><b>Disconnect the yellow and brown cable from the controller side. Turn your meter to an ohm or resistance scale. Place the red probe of your meter on the yellow wire's terminal and the black probe on the brown wire's terminal. Take the resistance reading across the motor. A reading between 0.3ohm and 2-4ohm should appear. If the reading is higher than 4 ohm replace the brushes. DC brush wear is the result of mechanical friction and electrical corrosion.</b>  <b>If the reading indicates an open circuit armature try first replacing the brushes. If nothing happen replace the motor.</b></p>
<p><b>The driving speed forward direction is less than the speed in reverse direction</b></p>	<p><b>Check and correct the connections at M1 and M2 or wiring to motor. This problem occurs if the cables yellow and brown are reverse connected.</b></p>

--	--

## 8. THROTTLE POTENTIOMETER

The throttle controls both the speed and the direction of the scooter. Pushing the throttle in one direction the scooter moves forward and pushing in the other the scooter moves reverse

<p>Usually Forward is on the right hand and Reverse on the left hand. How can we reverse them without losing performances?</p>	<p>The throttle potentiometer is connected to Front board by one six –pin connector plugged into J4 header located on front board. Reverse Blue and Brown wires. In this case depressing the throttle with the left hand will select forward and the reverse direction will be selected using the right hand. Change the label of the for front and back !!</p>																		
<p>Is the potentiometer correct calibrated?</p>	<p>Turn the power off. Unplug the connector inserted in the header J4 located on the front board. Without depressing the throttle take the following resistance readings:</p> <ul style="list-style-type: none"> <li>- 1. Blue and Green</li> <li>- 2. Green and Brown</li> <li>- 3. Blue and Brown</li> </ul> <p>The value of the potentiometer resistance may range between 4.8Kohm and 5.2Kohm.</p> <table border="1" style="width: 100%;"> <tr> <td style="width: 5%;">1</td> <td>You should see 2400 – 2600 ohm</td> </tr> <tr> <td>2</td> <td>You should see 2400 –2600 ohm</td> </tr> <tr> <td>3</td> <td>You should see 4800 –5400 ohm</td> </tr> </table> <p>If the issues 1 and 2 have as result almost the same values then the potentiometer may be correctly centered within the controller’s neutral dead-band. If a voltage reading is preferred turn the power on and connect a voltmeter. Take three successive readings. The red probe is pushed first into terminal 2 of the J4 (Green wire) then into terminal 1 (blue wire) and finally into terminal 3 (brown wire). The black probe is pushed into terminal 4 of the same connector J4 (GND). Without depressing the throttle the following readings should appears:</p> <table border="1" style="width: 100%; margin-top: 20px;"> <thead> <tr> <th>Terminals</th> <th>Value</th> <th>Front board header</th> </tr> </thead> <tbody> <tr> <td>1 and 4</td> <td>About 4.5V</td> <td>J4</td> </tr> <tr> <td>2 and 4</td> <td>About 2.5V+/- 100mV</td> <td>J4</td> </tr> <tr> <td>3 and 4</td> <td>About 0.4V</td> <td>J4</td> </tr> </tbody> </table>	1	You should see 2400 – 2600 ohm	2	You should see 2400 –2600 ohm	3	You should see 4800 –5400 ohm	Terminals	Value	Front board header	1 and 4	About 4.5V	J4	2 and 4	About 2.5V+/- 100mV	J4	3 and 4	About 0.4V	J4
1	You should see 2400 – 2600 ohm																		
2	You should see 2400 –2600 ohm																		
3	You should see 4800 –5400 ohm																		
Terminals	Value	Front board header																	
1 and 4	About 4.5V	J4																	
2 and 4	About 2.5V+/- 100mV	J4																	
3 and 4	About 0.4V	J4																	
<p>The Status led indicator indicates throttle fault</p>	<p>Perform throttle potentiometer test as describe above. The goal of the test is to find out wires that are short-</p>																		

	<p>circuit, loose connections, no calibrated or damaged potentiometer. If they are good carry out test of the cable that connects controller with front board. Otherwise replace the Front board or replace the Controller.</p>
<p>While depressing the throttle to maximum with Forward Full speed selected the controller output voltage is less then 100%( total battery voltage less 1.5V)</p>	<p>Ensure the switch Low /High SPEED is working correctly. The controller should be reprogrammed. The value of the parameter THRTL GAIN should be increased in order to fit the electric span of the throttle potentiometer with the controller.</p>

## **9. OPERATIONAL TESTS**

### **9.1. PERFORMING OPERATIONAL TESTS USING THE HAND-HELD PROGRAMMER.**

The programmer is a menu-driven device powered by the host controller via a 4-pin connector located on the controller. The handheld programmer allows programming, testing, and diagnosing the controller.

<b>A</b>	<b>Connect the hand-held programmer</b>
<b>B</b>	<b>Turn the key switch on. The programmer should power up with an initial display. It displays the controller's model number, date of manufacture and software release. Notice the software release number. The last one is 06.</b>
<b>C</b>	<b>Put the programmer in TEST mode by pressing the &lt;TEST&gt; key. The LED at the corner of the key lights up. Four lines of the menu are displayed at a time. Scroll down within the menu until the desired item is positioned on the four lines window.</b>

<b>D</b>	<b>HEATSINK C</b>	<i>value</i>		<i>Value</i> means controller internal temperature. If displayed value exceeds 92-Celsius degrees the controller will enter the thermal protection.
	<b>THROTTLE %</b>	<i>value</i>		<i>Value</i> means percent of applied throttle.
	<b>SPD LIMIT POT</b>	100		Constant value 100. Faulty system or controller if different than 100.
	<b>BATT VOLTAGE</b>	<i>value</i>		The actual total battery voltage when throttle is applied
	<b>BDI</b>	<i>value</i>		<i>Value</i> means percent of battery remaining capacity. Full charged battery means 100%
	<b>MODE INPUT A</b>	ON	OFF	The reading could be ON or OFF depending of Low /High SPEED switch
	<b>REVERSE INPUT</b>	OFF		Constant value OFF; not used in application
	<b>INHIBIT IN</b>	OFF	ON	The reading could be On or OFF. When reading is ON the drive is inhibited
	<b>EM BRAKE DRV</b>	ON	OFF	The reading could be On or OFF. With throttle applied the value is ON. When releasing the throttle the value is changed to OFF
	<b>MAIN CONT</b>	ON	OFF	<i>Displays the status of the main relay located in the controller. With throttle applied the status should be on. If it remains off the controller has detected a fault and the driving is inhibited</i>
	<b>MOTOR R</b>	400		Constant value
	<b>PUSH ENABLE IN</b>	OFF		OFF; not used in application
<p>Before tests enter the Programming mode and change the parameter THRTL AUTOCAL from OFF to ON. Other alternative is putting the vehicle's front wheel in freewheeling mode.</p>				
<b>E</b>	<p><b>LOW /HIGH SPEED SW</b> Turn the switch into Low Speed position. The switch's lamp is off. The LCD shows MODE INPUT A OFF. Turn the switch into High Speed position. The switch's lamp glows. The LCD shows MODE INPUT A ON.</p>			
<b>F</b>	<p><b>INHIBIT TEST</b> Plug in the charger's DC outlet into the charging socket. Panel display turns off. The handheld programmer LCD shows that INPUT IN was changed from OFF to ON. Take out the charger's plug and turn the motor cap knob to release the parking brake. The horn warns continuously and the LCD shows INPUT IN ON. The panel display works normally indicating the battery remaining capacity and controller status.</p>			
<b>G</b>	<p><b>Throttle mechanical and electrical span test</b> Squeeze the throttle (operation lever) in either direction. You should notice:</p> <ul style="list-style-type: none"> <li>✓ the motor turns forward or reverse direction corresponding which way you operate the throttle.</li> <li>✓ the motor should run proportionately faster with increasing throttle.</li> <li>✓ the handheld programmer's LCD shows: MAIN CONT ON EM BRAKE DRV ON THROTTLE % increasing and decreasing value shown</li> <li>✓ ensure that at maximum lever's mechanical travel the reading is 100%</li> </ul>			
<b>H</b>	<p><b>Battery voltage reading</b> While throttle is applied the handheld programmer's LCD shows the total voltage battery.</p>			

## 10. DIAGNOSTICS

### 5.1 Diagnosing and troubleshooting using programmer diagnostics mode

Connect the programmer. Turn the key switch on. Press the DIAGNOSTICS key.

The display should indicate NO FAULTS FOUND. If there is a problem the Status indicator will flash a diagnostic code and the programmer will display a diagnostic message.

List of messages:

You should read the explanations included in the paragraph 1.2 too.

PROGRAMMER DISPLAY	EXPLANATION	Status Led code
THERMAL CUTBACK	Cut back due to over-temperature	(1,1)
THROTTLE FAULT 1	Throttle input voltage out of range	(1, 2)
SPD LIMIT POT FAULT	Loose connection Front board faulty Controller faulty	(1, 3)
LOW BATTERY VOLTAGE	Battery voltage too low	(1, 4)
MAIN OFF FAULT	Main controller driver fault	(2,1)
MAIN ON FAULT	Main controller driver fault	(2,4)
MAIN CONT WELDED	Main controller driver fault	(2, 2)
MAIN ON FAULT	Main controller driver fault	(2, 4)
PROC / WIRING FAULT	HPD fault is present more than 10s The fault caused by misadjusted potentiometer, broken throttle potentiometer or broken throttle mechanism	(3,1)
PRECHARGE FAULT	Controller failure or low battery voltage	(3, 3)
HW FAILSAFE	Motor voltage fault	(4, 2)
EEPROM FAULT	EEPROM Fault-controller faulty	(4, 3)
NO KNOWN FAULTS		
POWER SECTION FAULT	Check controller and motor power connection	(4, 4)
HPD	The HPD feature prevents controller output if the vehicle is powered when the throttle is not in neutral. If the controller latches cycle the key switch for resuming.	(3, 4)

### EXAMPLE 1

*Symptom: the scooter appears to run only in reduced speed range.*

The handheld programmer set in Diagnostic mode indicates NO KNOWN FAULTS.

Put the programmer in TEST mode and scroll down to observe the line MODE INPUT A.

Turn the switch LOW / HIGH switch into LOW position.

You should see MODE INPUT A OFF. Turn the switch into HIGH position. You should see MODE INPUT A ON. If the reading does not appear correctly proceed by:

- Checking the cable that interfaces Front board with the Controller.
- Checking the switch connection with Front board
- Checking and replacing the switch

If the reading is correct then replace the controller.

## **EXAMPLE 2**

*Symptom: After charging the battery gauge display indicates less than 20% remaining capacity by flashing the LED 1.*

**Powered up the scooter. Connect the handheld programmer and select DIGNOSIS mode**

**The handheld programmer displays NO KNOWN FAULTS.**

**Select TEST mode.**

**Scroll down to observe the line BDI *value*. If the *value* is 100%:**

- ✓ **Check and replace the cable that interfaces the controller with the front board**
- ✓ **Replace Front board**
- ✓ **Replace the cable that connect Front board with Display board**
- ✓ **Replace Display board**

**If the handheld programmer shows BDI 0% you should check the charging electric circuitry (wiring, charging board adapter board, charging fuse, power cabling and battery connections).**

**After performing this test connect the charger and powered it up.**

**When Green led charger's indicator is turned on state take a reading of the total battery voltage.**

**If the value shown is greater than 26V during at least 10 minutes and BDI value remains 0% you have to replace the controller. If you observe BDI value updates from 0 to 100 percent turn off the scooter. Wait for 3 to 5 minutes and turn it on and read BDI value again. If BDI line shows 0% the controller is defective. If the BDI shows 100% the problem resides in incorrect charging or defective charger.**

## **11. PROGRAMMING**

**In PROGRAM mode, accessed by pressing the PROGRAM key all the adjustable parameters are displayed four at a time along with their present settings.**

**You can drive with the handheld programmer connected. For safety reasons accessing some critical parameters will cause the controller to trip. This is intentional and the controller can be simply reset by switching off and on again.**

**Resetting parameters to non-compatible values could result in an unsafe set-up of the vehicle and for the user. The recommended values are included in the listings release**

**Contact our company if you need any advice in programming.**

## **12. REPLACEABLE PARTS LIST:**

<b>Controller</b>	<b>- PC00121 or PC00099</b>
<b>Front Board</b>	<b>- PC00100</b>
<b>Charger board</b>	<b>- PC00106</b>
<b>Display board</b>	<b>- PC00103</b>
<b>F1 SMT fuse slow blow 2.5A</b>	<b>- FU00010</b>
<b>F2 slow blow fuse 1.25A</b>	<b>- FU00005</b>



12	1	USER MANUAL ENG. SL-3	PRSL001
11	1	CHARGER 2A	FT00232 + supply cable
10	1	SEAT SL-2 BLACK ASSY.	ASSL030 (See page 7)
9	1	REAR BASKET SL-3 ASSY.	ASSL028
8 (option)	1	BATTERY LEFT 24H AS.	ASSL025
7 (option)	1	BATTERY RIGHT 24H AS.	ASSL024
6	1	POWER UNIT SL-3	ASSL021 (See page 6)
5	1	BATTERY COVER SL-3 ASSY.	ASSL020
4	1	BATTERY LEFT 18H SL-3 AS.	ASSL016 (See page 9)
3	1	BATTERY RIGHT 18H SL-3 AS.	ASSL015 (See page 8)
2	1	TILLER SL-3 ASSY.	ASSL005 (see page 5)
1	1	FRAME SL-3 ASSY.	ASSL003 (See page 4)
<b>ITEM.</b>	<b>QTY.</b>	<b>NAME</b>	<b>PART/NO DRAW/NO</b>

Do not scale from drawing.			Draw.	Michael	Drawing no.	 AFIKIM ELECTRIC MOBILIZERS KIBUTZ AFIKIM 15148 ISRAEL TEL: 972-4-6754814 FAX: 972-4-6751456 E-mail: mainbox@afiscooters.com Website: www.afiscooters.com		
Approved only with stamp			Checked:				FTSL999a	
		△e	Production:		Part name: SUPPERLIGHT SL-3 ASSY.			
		△d	Confirme:					
		△c	Tolerance.		Date	Scale	Page: 1	Cat. No.
		△b	Linear	Angular				
15 - 7 - 04	x	△a	±0.3	±1°	15 - 7 - 04		Of: 9	FTSL001
Date.	Conf.	Update.						



DETAIL A  
SCALE 1 : 2

DETAIL B  
SCALE 1 : 4

DETAIL C  
SCALE 1 : 4

Page:	2	DATE	Scale	tolerance			Drawing no.	Cat. No.	Part name:	 AFIKIM ELECTRIC MOBILIZERS KIBUTZ AFIKIM 15148 ISRAEL TEL: 972-4-6754814 FAX: 972-4-6751456 E-mail: mainbox@afiscooters.com Website: www.afiscooters.com
Of:	9	26-7-04	X	holes dia.	linear	angular				

### REAR-SUPPLY SL-3

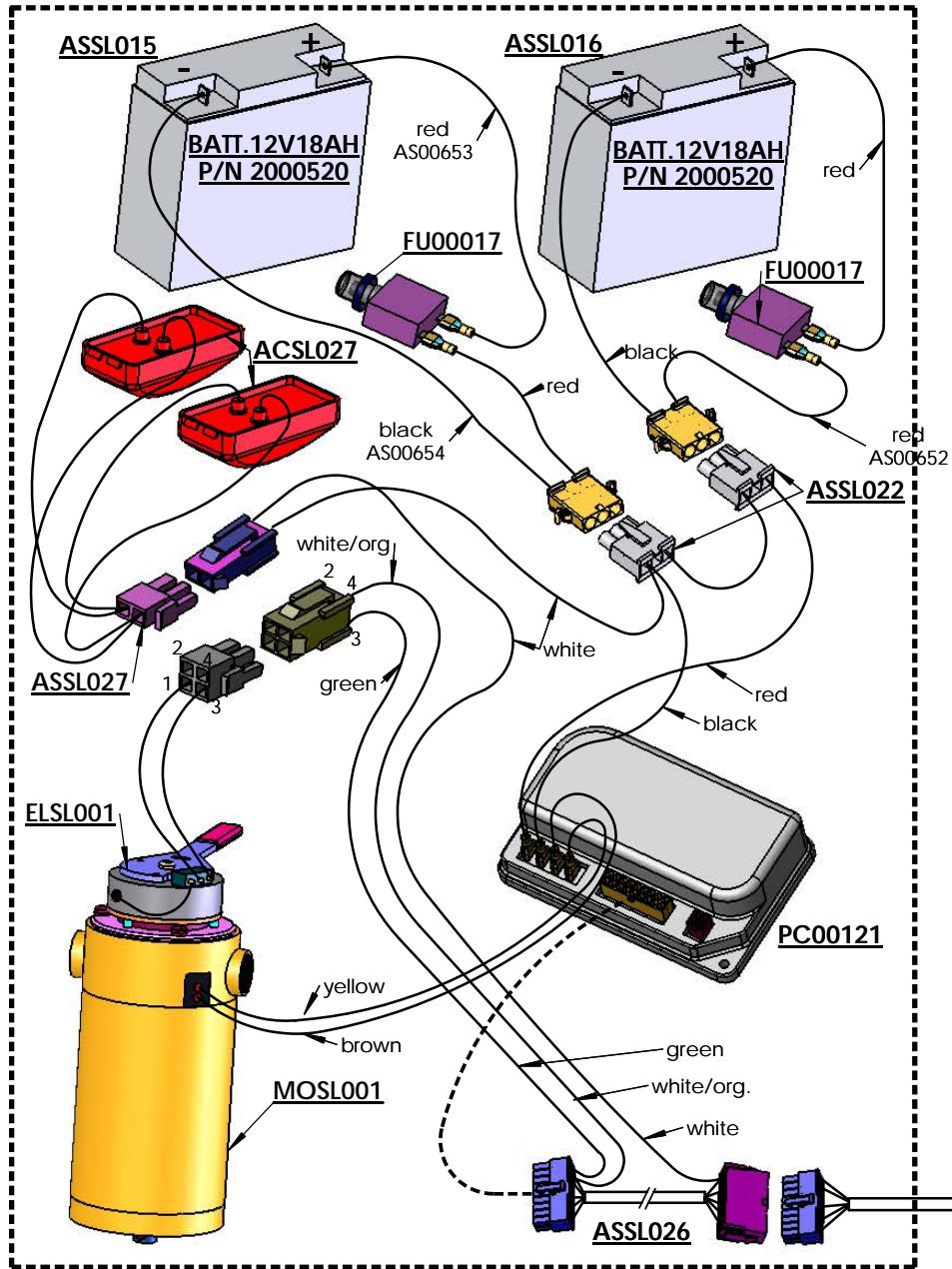

### FRONT-TILLER SL-3

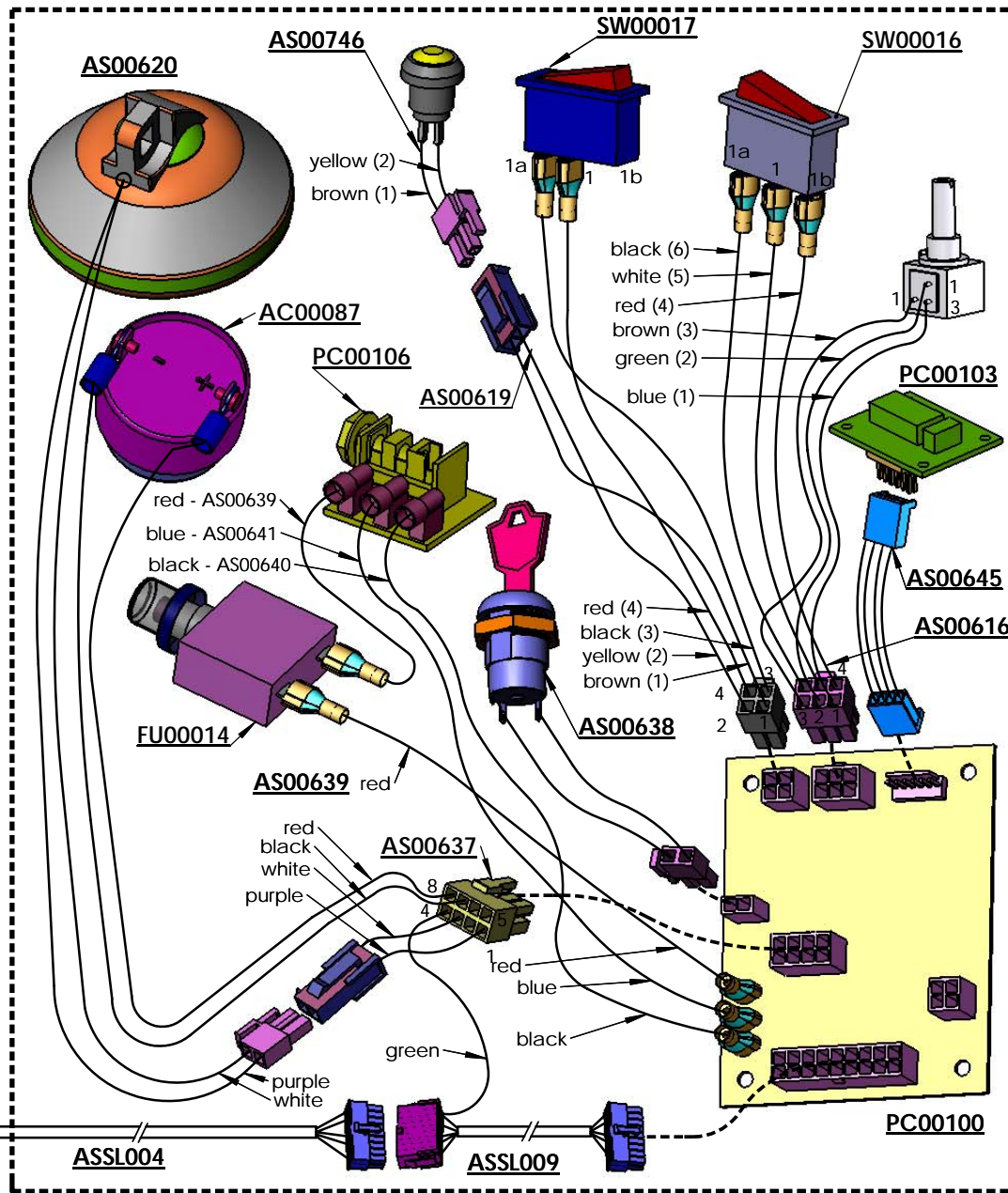

Page: 3	DATE 26-7-04	Scale X	tolerance			Drawing no. FTSL999a	Cat. No. FTSL001	Part name: SUPERLIGHT SL-3	 AFIKIM ELECTRIC MOBILIZERS KIBUTZ AFIKIM 15148 ISRAEL TEL: 972-4-6754814 FAX: 972-4-6751456 E-mail: mainbox@afiscooters.com Website: www.afiscooters.com
			holes dia. ±0.3	linear ±0.1	angular ±1°				
Of: 9									

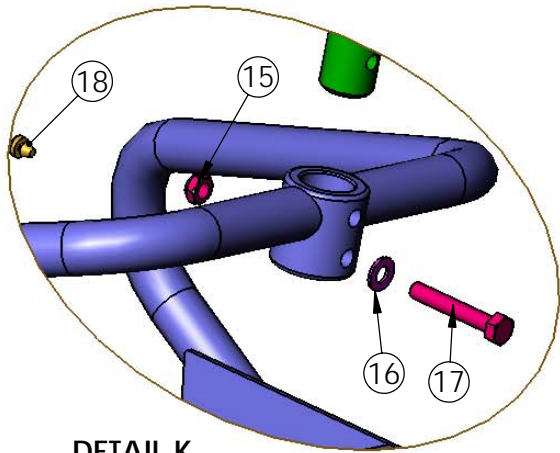

**DETAIL K**  
**SCALE 1 : 3.5**

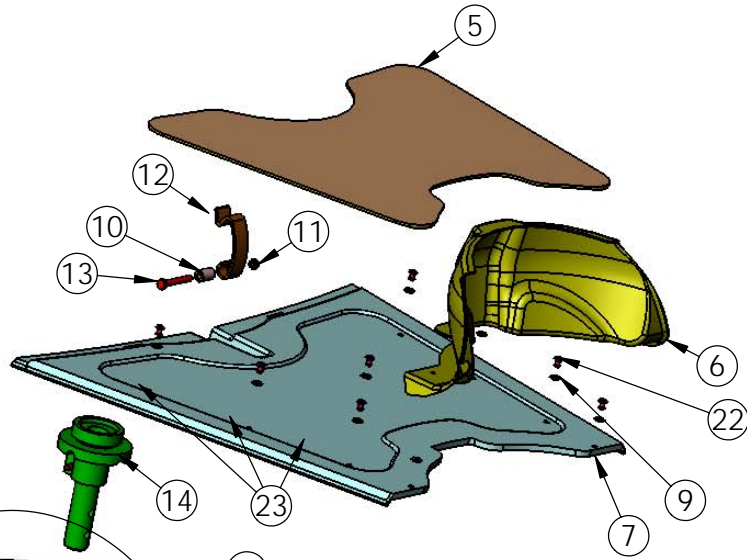

**DETAIL I**  
**SCALE 1 : 3**

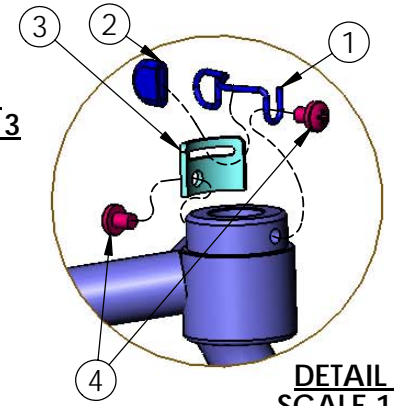

**DETAIL J**  
**SCALE 1 : 3**

**DETAIL M**  
**SCALE 1 : 3**

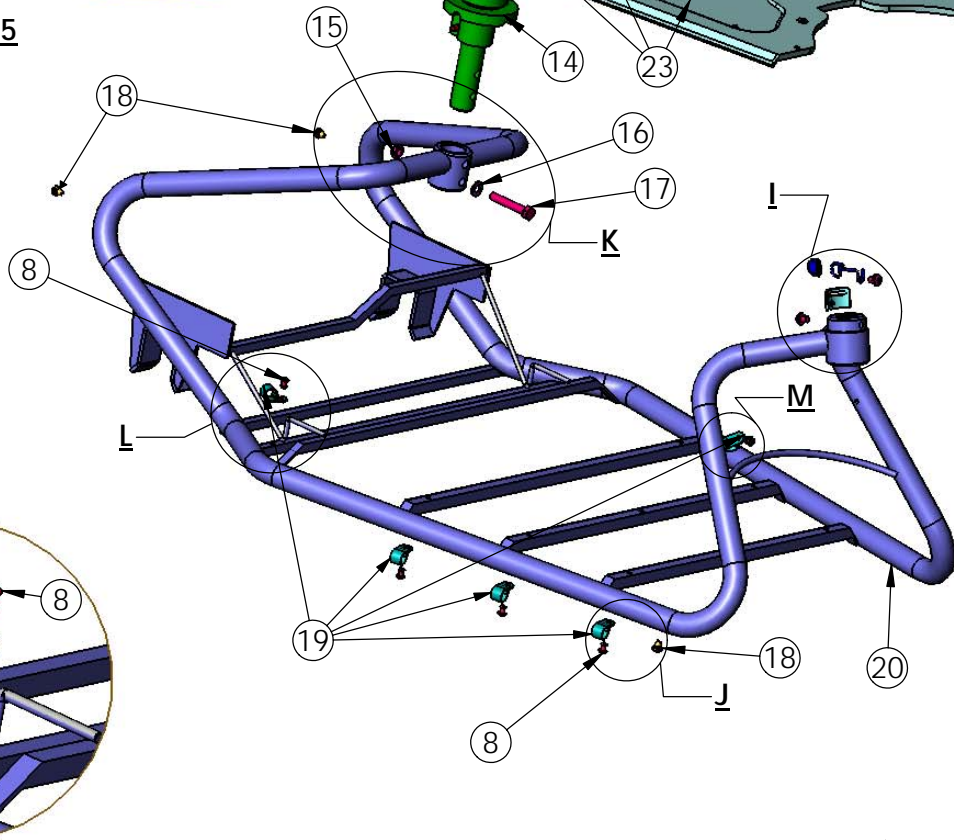
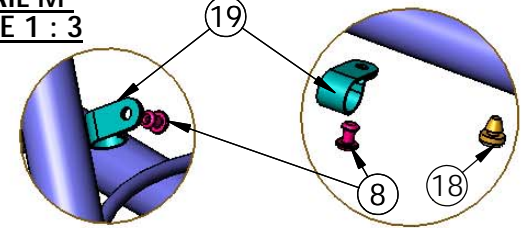

**DETAIL L**  
**SCALE 1 : 3**

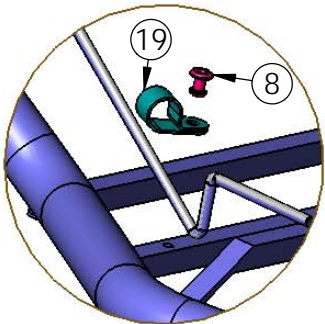

23	0.40m	strap 70x25(x4) , 50x25(x2)	AC00132
22	9	RIVET 5/12	SC00250
21	1	MAIN HARNESS SL-3 (see page 3)	ASSL004 ASSL004*
20	1	FRAME SL-3	MPSL001 MPSL001*
19	5	CLAMP MAIN HARNESS SL-3	HW00120
18	4	PLASTIC PIN D=4.7	HW00092
17	1	SCREW HEX. M8X50 GALV.	9010398
16	1	WASHER M8	WA00057
15	1	NUT HEX.NYLON M8 GALV.	9010311
14	1	SEAT BASE ADAPTOR SL2	MP00588 MP00588*
13	1	SCREW M6X45	9010177
12	1	CLIP PLASTIC BAT. COVER	IP00033 SC11014*
11	1	NUT HEX.NYLON M6 GALV.	9010181
10	1	CLIP PLASTIC BUSHING	IPSL004
9	9	WASHER GALV. M5	WA00002
8	5	RIVET 4/12 BLACK ANODIZE	9010352
7	1	PLASTIC FLOOR SL3	VPSL003 VPSL003*
6	1	MUD GURD	VP00106 VP00106*
5	1	CARPET	HWSL001
4	2	SCREW CAP M6*8+GALV.	SC00042
3	1	SPRING LIMITER SUPERL.	MP00442 MP00442*
2	1	COVER PLAST STEERING SPRING	IP00043 IP00043*
1	1	SPRING LOCK STEER PIN	SP00004 SC11013*
<b>NO.</b>	<b>QTY.</b>	<b>NAME</b>	<b>PART/NO</b> <b>DRAW/NO</b>

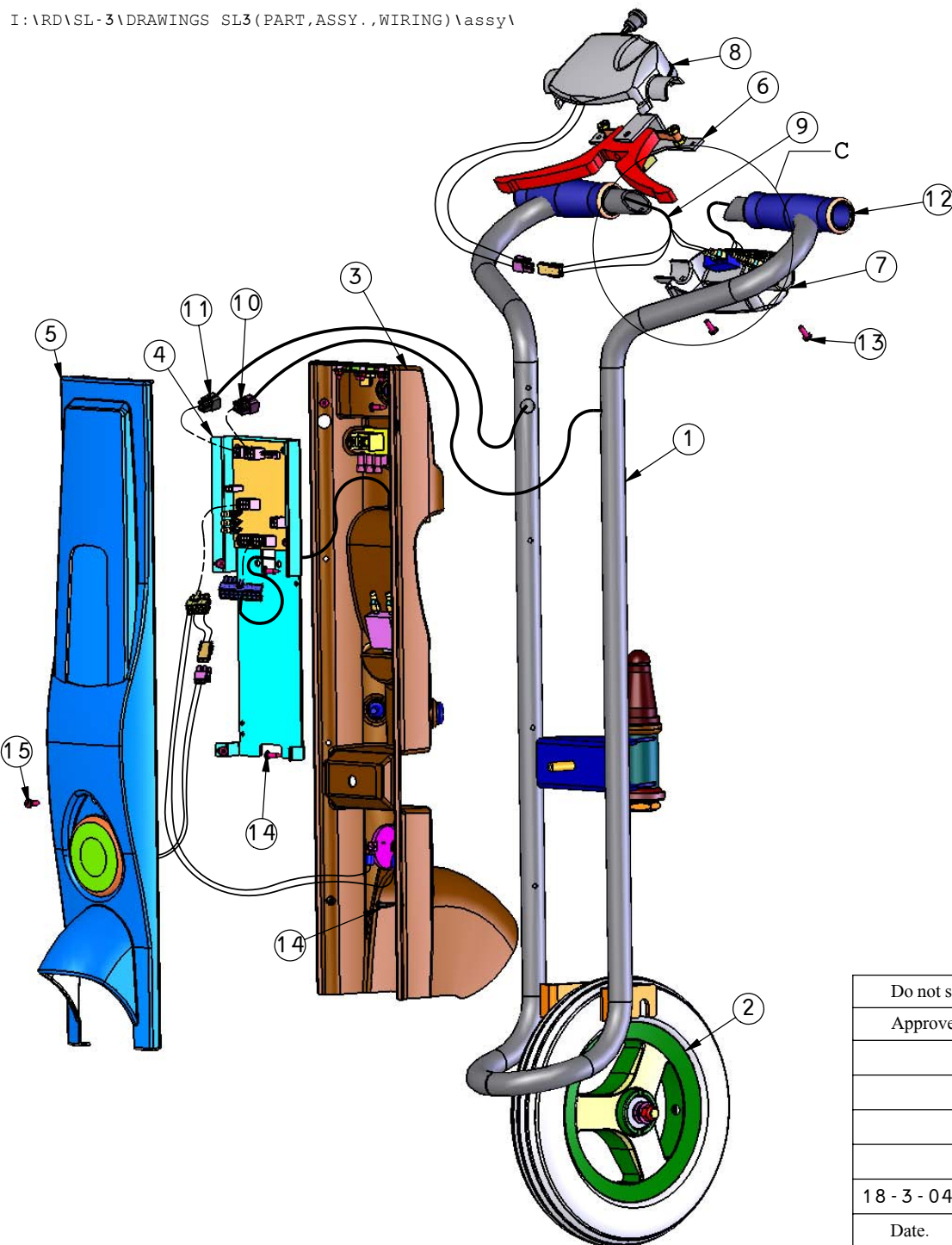

C (1 : 3)

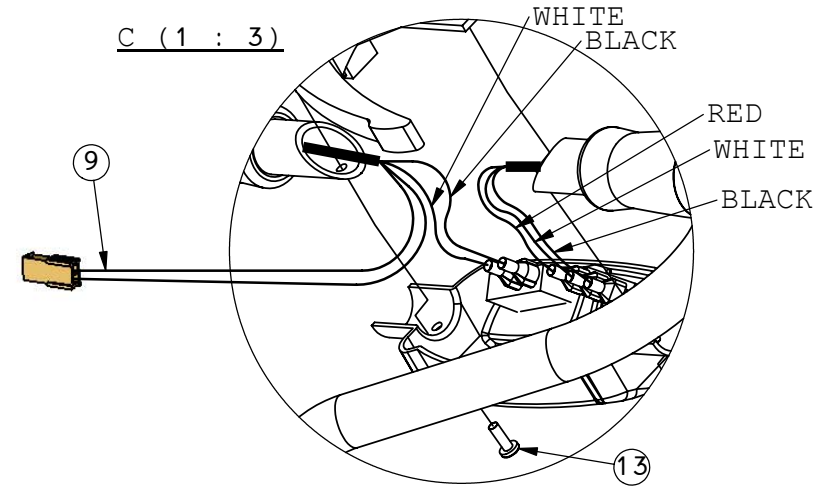

15	1	SCREW R/H PHILIP M4*10	SC00173
14	8	SCREW PAN PHL.TAP.4.2*9.5	SC00085
13	2	SCREW PHILIPS M4X12	SC00056
12	2	GRIP F/HANDLE RUBBER MATR	VP00026
11	1	CONEC. 4P CVILUX	CO00083
10	1	CONEC. 6P CVILUX	CO00080
9	1	LIGHT SW.CON. SL2 ASSY.	AS00619 AS00619*
8	1	COVER SP.CO. SL-3 ASSY.	ASSL013 ASSL013*
7	1	COVER BO.SP. SL-3 ASSY.	ASSL012 ASSL012*
6	1	SPEED CON. SL-3 ASSY.	ASSL011 ASSL011*
5	1	COVER ELECT. SL-3 ASSY.	ASSL014 ASSL014*
4	1	ELECTRIC SYST. SL-3	ASSL010 ASSL010*
3	1	ELECTRIC HOUSE SL-3	ASSL008 ASSL008*
2	1	FRONT WHEEL SL-3 ASSY.	ASSL007 ASSL007*
1	1	TILLER FRAME ASSY. SL-3	ASSL006 ASSL006*
ITEM	QTY.	NAME	PART/NO DRAW/NO

Do not scale from drawing.			Draw.	Michael	Drawing no.	 AFIKIM ELECTRIC MOBILIZERS KIBUTZ AFIKIM 15148 ISRAEL TEL: 972-4-6754814 FAX: 972-4-6751456 E-mail: mainbox@afiscooters.com Website: www.afiscooters.com			
Approved only with stamp			Checked:						
		$\triangle_e$	Production:		Part name:				
		$\triangle_d$	Confirme:			TILLER SL-3 ASSY.			
		$\triangle_c$	Tolerance.		Date		Scale	Page: 5	Cat. No.
		$\triangle_b$	Linear	Angular					
18-3-04	x	$\triangle_a$			18-3-04		Of: 9	ASSL005	
Date.	Conf.	Update.	$\pm 0.1$	$\pm 1^\circ$					

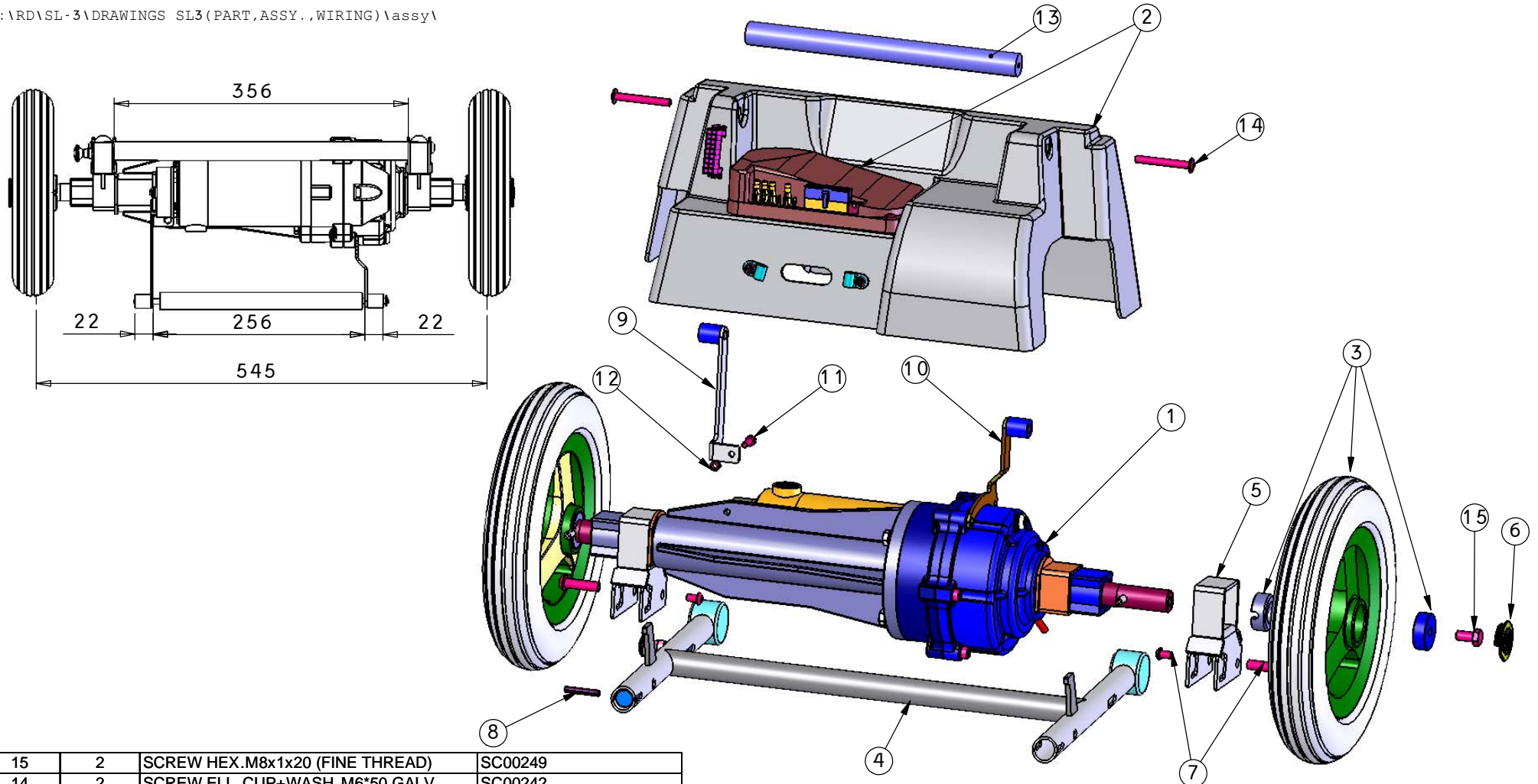



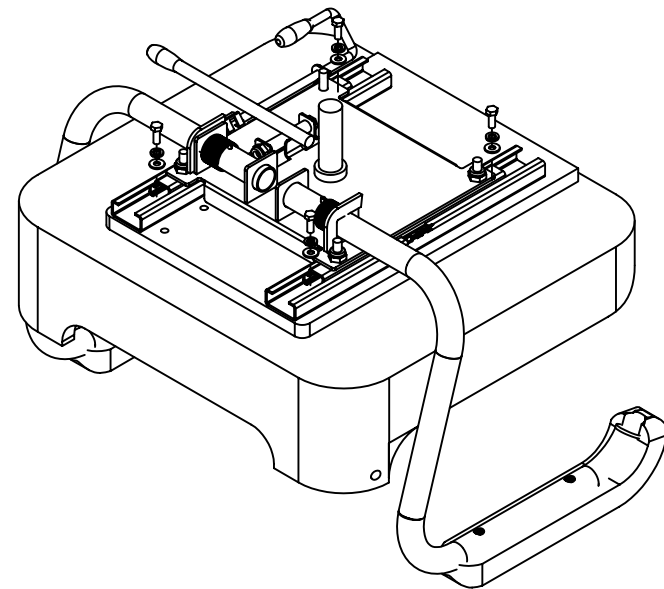
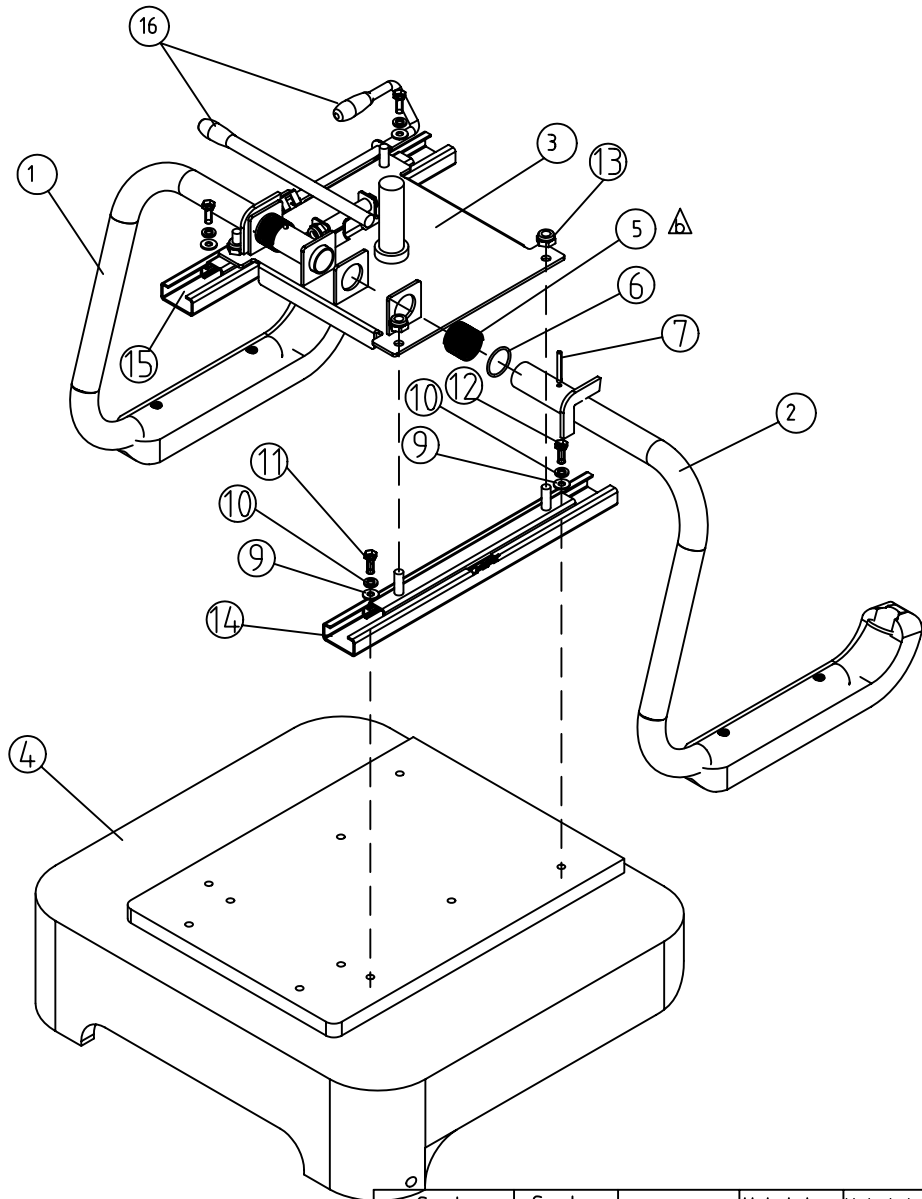

15	2	SCREW HEX.M8x1x20 (FINE THREAD)	SC00249
14	2	SCREW ELL.CUP+WASH.M6*50 GALV.	SC00242
13	1	HANDLE F/COVER SL-3	MPSL012 MPSL012*
12	1	HEX.LOCKNUT M5	9010317
11	1	SCREW HEX.M5*16 GALV.	9010315
10	1	PLATE 2 HOLES SL-3	MPSL014 MPSL014*
9	1	PLATE 1 HOLE SL-3	MPSL015 MPSL015*
8	1	SPIRAL PIN 5*35	SC00233
7	2	SCREW SHAFT R\ R/H ALLEN 8*30+M6	SC00224
6	2	CUP F/SUPERLIGHT WHEEL	IPSL005
5	2	METAL CLAMP PO.UN.SL3	MPSL010 MPSL010
4	1	CLAMP RELEASE SL -3 ASEA	ASSL019 ASSL019*
3	2	REAR WHEEL SL -3 ASSY.	ASSL018 ASSL018*
2	1	COVER F/POWER UNIT SL-3 ASS.	ASSL017 ASSL017
1	1	POWER UNIT SL3	ASSL001 ASSL001*
<b>ITEM</b>	<b>QTY.</b>	<b>PART NAME</b>	<b>Catalog no. Drawing No.</b>

Do not scale from drawing.			Draw.	Michael	Drawing no.	 AFIKIM ELECTRIC MOBILIZERS KIBUTZ AFIKIM 15148 ISRAEL TEL: 972-4-6754814 FAX: 972-4-6751456 E-mail: mainbox@afiscooters.com Website: www.afiscooters.com			
Approved only with stamp			Checked:						
		$\triangle_e$	Production:		FTSL999a	Part name: POWER UNIT SL-3 ASSY.			
		$\triangle_d$	Confirme:						
6-6-04		$\triangle_c$	Tolerance.		Date	Scale	Page: 6	Cat. No.	
20-4-04		$\triangle_b$	Linear	Angular					
8-3-04	x	$\triangle_a$	Date.	Conf.	Update.	8-3-04	Of: 9	ASSL021	
									$\pm 0.1$



	2	HW00101	TIPE F/SWIVER LEVER	16	
	1	MP00676	SLIDER LEFT	15	
	1	MP00675	SLIDER RIGHT	14	
	4	9010311	NUT NYLOCK M8	13	
	2	9010310	SCREW HEX. M6x16 GALV.	12	
	2	9010319	SCREW HEX. M6x30 GALV.	11	
	4	9010061	SPRING WASHER INT. - M6	10	
	4	9010096	WASHER M6	9	
	1	AC00136	Adapter wrench	8	
	2	9010209	PIN SPLITED 3.2x45 BN912	7	
	2	2000036	O RING	6	
	2	K4x4.0350	1000710	PRESS.SPRING.HND.REST	5
	1	SEE TABLE	PLAST.FOLD SEAT GRAY/BLACK FIRE RET	4	
	1	MP00587a	MP00587	SEAT BASE SL2	3
	1	AS00605a	AS00605	LEFT ARMREST ASSY.	2
	1	AS00604a	AS00604	RIGHT ARMREST ASSY.	1

REMARKS	QUANT.	DRAWING NO./ CAT NO.	PART NAME		NO.				
DO NOT SCALE FROM DRAWING	DRAW	MICHAEL	DRAWING NO.		 <b>AFIKIM ELECTRIC VEHICLES</b> KIBBUTZ AFIKIM 15148 ISRAEL TEL: 972-6-6754814 FAX: 972-6-6751456 E-mail: mainbox@afiscooters.co.il Website: www.afiscooters.co.il				
APPROVED ONLY WITH STAMP	CHECK		FTSL999a						
	PRODUCT		PART NAME						
	CONFIRM		SEAT SL2 ASSY.						
30-04-04	4980		ANGEL	LINER	DATE	SCALE	PAGE	7	CAT. NO.
25.12.01	4279		0-5 ±0.1	0-6 ±0.1	11-1-00		OF	9	See Table
11-1-00	4069		5-30 ±0.2	30-200 ±0.3	DATE	SCALE	PAGE	7	CAT. NO.
			30-90 ±0.3	200-1000 ±0.5	11-1-00		OF	9	See Table
					DATE	SCALE	PAGE	7	CAT. NO.
					11-1-00		OF	9	See Table

Seat Assembly	Seat + Upholstery	Seat Plast	Upholstery FOR Seat	Upholstery For Back
SL-2 AS00631	SE00009	SE00008	AC00065	AC00064
SL-3 ASSL030	ASSL029	SE00011	AC00105	AC00109

 UPDATE PART #5 MARK

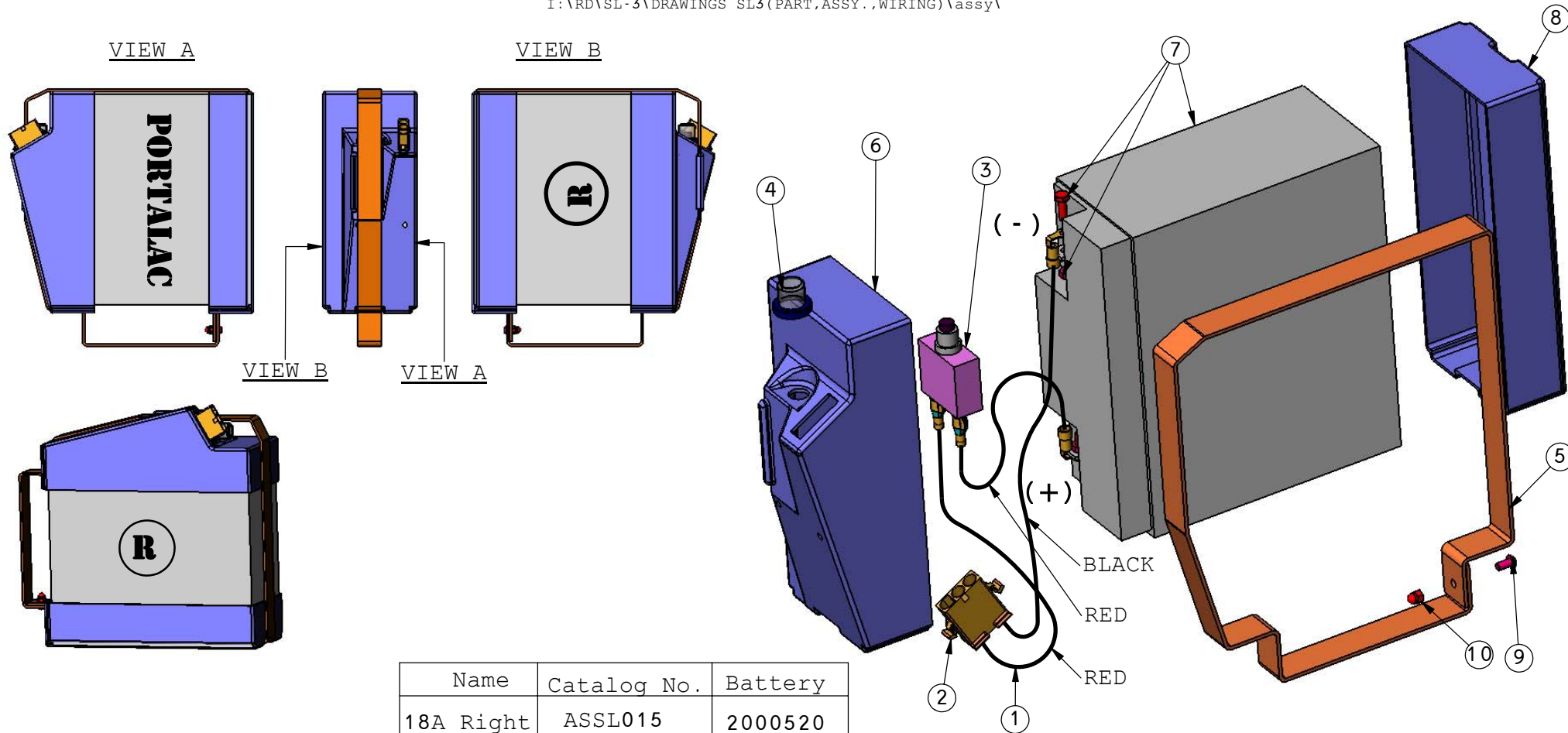

Name	Catalog No.	Battery
18A Right	ASSL015	2000520
21A Right	ASSL031	AC000151



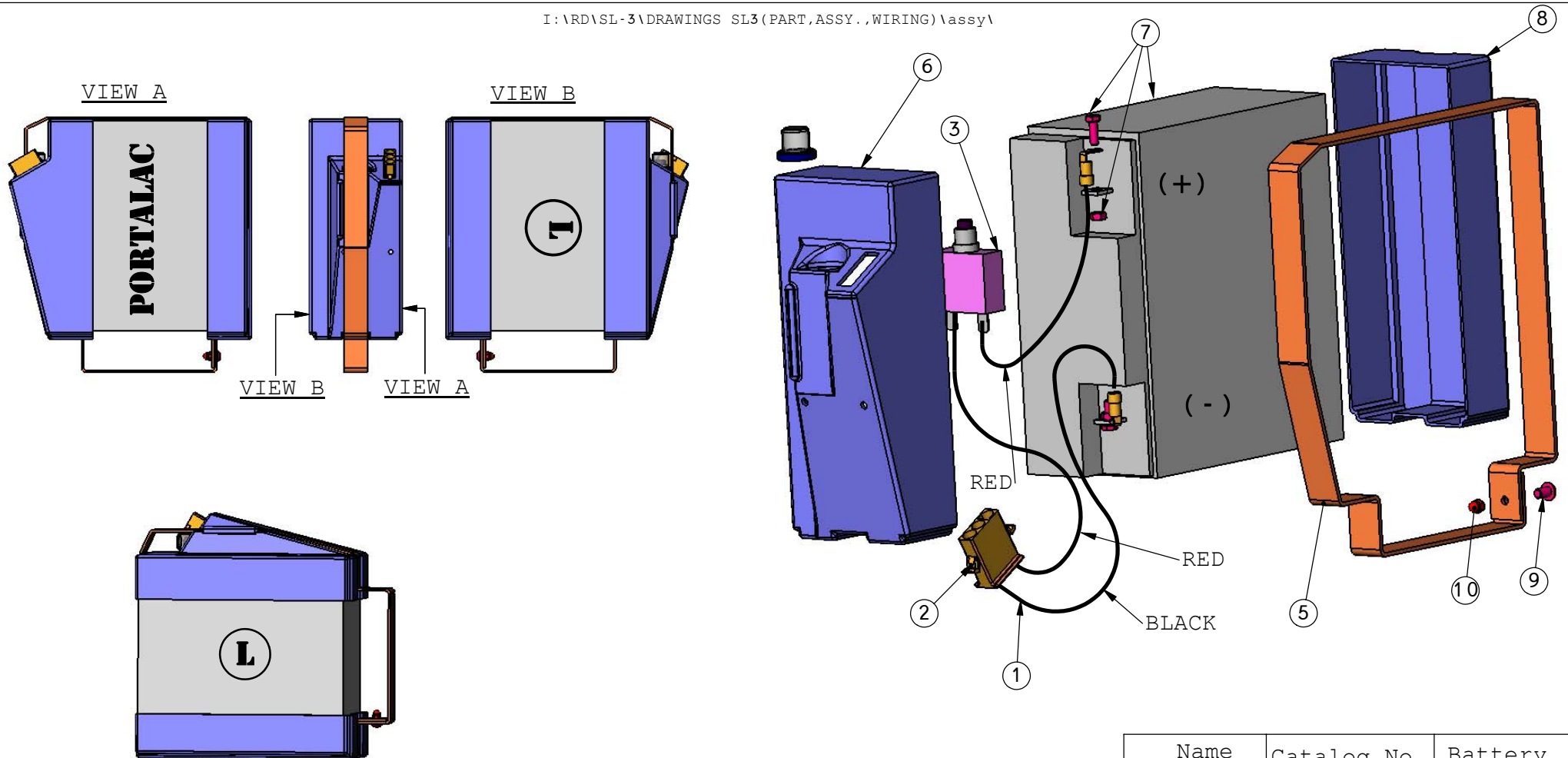

ITEM	QTY.	NAME	PART/NO	DRAW/NO
10	1	HEX DOMEND NUT M5	9010444	
9	1	SCREW ALLEN R/H M5*12 GLVA.	9010396	
8	1	COVER F/BAT.REAR 15A	2000676	2000676*
7	1	BATTERY 12V, 18/21AH	See Table	
6	1	BAT.COVER LEFT SL2	MP00595	MP00595*
5	1	BAND F/BATTERY SL-3	MPSL011	MPSL011*
4	1	RUBBER COVER F/FUSE AUTO/ZING	HW00082	
3	1	FUSE 30A (ZE-700-30A) +CAP	FU00017	
2	1	CONNECT.42179 3P FEMA.	CO00065	CO00065*
1	1	BATT.WIRE SL2 ASSY	AS00655	

Do not scale from drawing.			Draw.	Michael	Drawing no.	 AFIKIM ELECTRIC MOBILIZERS KIBUTZ AFIKIM 15148 ISRAEL TEL: 972-4-6754814 FAX: 972-4-6751456 E-mail: mainbox@afiscooters.com Website: www.afiscooters.com			
Approved only with stamp			Checked:						
5-7-04			Production:		FTSL999a	Part name: BATT.RIGHT 18/21A SL-3 ASSY.			
			Confirme:						
03-05-04			Tolerance.		Date	Scale	Page: 8	Cat. No.	
			Linear	Angular					
8-3-04			x		8-3-04		Of: 9	See Table	
Date.	Conf.	Update.	±0.1	±1°					



Name	Catalog No.	Battery
18A Left	ASSL016	2000520
21A Left	ASSL032	AC000151

ITEM	QTY.	NAME	PART/NO	DRAW/NO
10	1	HEX DOMEND NUT M5	9010444	
9	1	SCREW ALLEN R/H M5*12 GLVA.	9010396	
8	1	COVER F/BAT.REAR 15A	2000676	2000676*
7	1	BATTERY 12V,18/21AH	See Table	
6	1	BAT.COVER LEFT SL2	MP00595	MP00595*
5	1	BAND F/BATTERY SL-3	MPSL011	MPSL011*
4	1	RUBBER COVER F/FUSE AUTO/ZING	HW00082	
3	1	FUSE 30A (ZE-700-30A) + CAP	FU00017	
2	1	CONNECT.42179 3P FEMA.	CO00065	CO00065*
1	1	BATT.WIRE SL2 ASSY	AS00655	

Do not scale from drawing.			Draw.	Michael	Drawing no.	 AFIKIM ELECTRIC MOBILIZERS KIBUTZ AFIKIM 15148 ISRAEL TEL: 972-4-6754814 FAX: 972-4-6751456 E-mail: mainbox@afiscooters.com Website: www.afiscooters.com				
Approved only with stamp			Checked:							
			Production:		FTSL999a	Part name: BATTERY LEFT 18A SL-3 ASSY.				
			Confirme:							
5-7-04					Tolerance.		Date			
24-06-04										
3-05-04					Linear	Angular	Date			
8-3-04	x				±0.1	±1°				
Date.	Conf.	Update.					8-3-04	Scale	Page: 9	Cat. No.
							Of: 9	See Table		

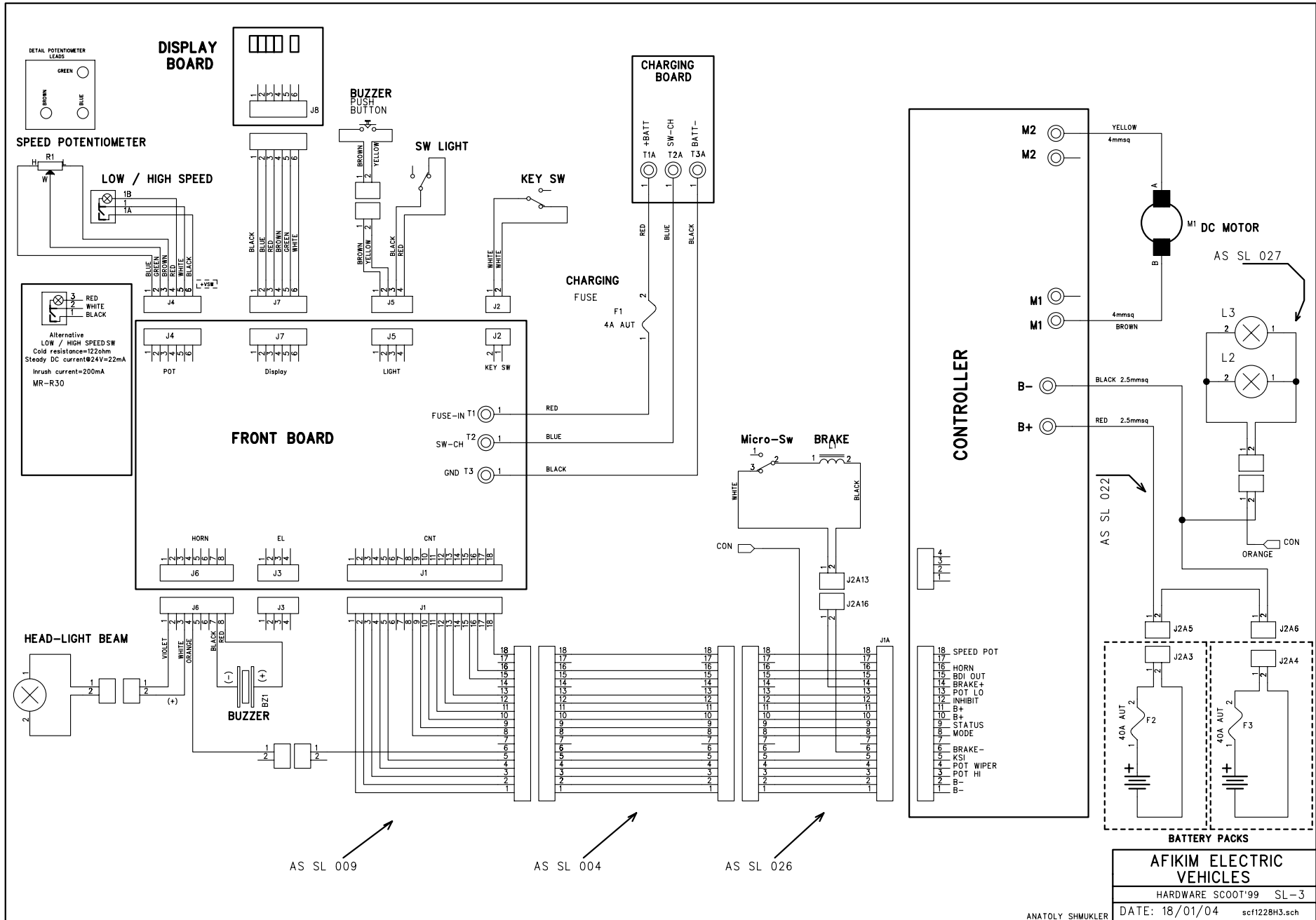

PARAMETER NAME	Caddy. SL2, SL3	
	VALUE	
<b>Beeper Sloid</b>		OFF
MAIN C/L		45
MOTOR R		100
IR COMP COEFF		50
KEY OFF DECEL		1.2
TREMOR COMP		2
ACCEL MAX SPEED		2.6
ACCEL MIN SPEED		2.2
DECEL MAX SPEED		0.8
DECEL MIN SPEED		1.2
E STOP		2
REV ACCEL MAX		1.2
REV ACCEL MIN		1
REV DECEL MAX		1
REV DECEL MIN		1
M1 MAX SPD		60
M2 MAX SPD		100
M1 MIN SPD		30
M2 MIN SPD		60
M1 REV MAX SPD		40
M2 REV MAX SPD		50
REV MIN SPD		30
GEAR SOFTEN		50
SOFT START		40
RAMP SHAPE		50
BDI FULL VLTS		24.6
BDI EMPTY VLTS		20.0
<b>BDI RESET TIME</b>		10
BDI RESET		25.6
SLEEP DLY		0
BRAKE DLY		0.4
CREEP SPD		6
THRTL TYPE		0
THRTL DEADBAND		15
THRTL GAIN		1.6
THRTL AUTOCAL		OFF
SPD SCALER		27
HIGH PEDAL DIS		ON
FAULT BEEP		OFF
SEAT LIFT		OFF
BRAKE FLTS		ON
SL BRAKE FLTS		OFF
<b>USL</b>		OFF
PUSH SPD		32