

---

# **SUPERLIGHT**

## **Scooter**

### **User's Manual**



**AFIKIM ELECTRIC VEHICLES**

#### **WARNING**

***Read carefully before assembly, disassembly and operating the SUPERLIGHT. If you do not fully understand any part of this Manual, please contact your dealer or any of our service centers - as injury or damage may occur from misuse.***

**WARNING**

*Electromagnetic Interference (“EMI”) can cause powered vehicles to behave erratically, which could be dangerous to the user. For your safety and protection, it is IMPERATIVE that you take time to read Chapter 11 (“EMI WARNING”) before operating SUPERLIGHT or any other powered vehicle.*

*If further clarification is required, please contact your dealer or any of our service centers: see the back cover of this User’s Manual.*

*The SUPERLIGHT passed the EMI testing: See Chapter 11.*

*Serial Number Label is affixed to the Tiller: See Fig 10.*

**CONTENTS**

<b><u>Subject</u></b>	<b><u>Page</u></b>
CHAPTER 1 - DELIVERY and UNPACKING .....	1
CHAPTER 2 -ASSEMBLY .....	3
CHAPTER 3 -OPERATING INSTRUCTIONS .....	17
CHAPTER 4 -DISASSEMBLY .....	25

CHAPTER 5 -THE CHARGER .....	33
CHAPTER 6 - STORING IN CAR .....	37
CHAPTER 7 -TROUBLESHOOTING .....	39
CHAPTER 8 -SAFETY INSTRUCTIONS .....	42
CHAPTER 9 -SERVICE .....	44
CHAPTER 10 -SPECIFICATIONS .....	47
CHAPTER 11 -EMI WARNING .....	49

**CHAPTER 1 - DELIVERY and UNPACKING**

The **SUPERLIGHT Scooter** is delivered to you packed in 2 **Cardboard Boxes** .

**Note:** *The boxes weights 30+28kg (66+62 lb.) - do NOT attempt to lift it without assistance.*

### **1.1 Unpack as follows (See Fig. 1)**

- a. Place boxes on floor with side **up** as marked by the arrows on the side of the box.
- b. Cut the **Plastic Bands**.
- c. Remove the cardboard **Top Cover**.
- d. Remove all parts from the boxes (and lay on the floor)
- e. Identifying the **SUPERLIGHT** Components (**See Fig. 1**)

- (1) Batteries Cover (6) Charger
- (2) Rear Wheels (7) Seat Adapter
- (3) Frame (8) Tiller
- (4) Seat (9) Rear Basket
- (5) Batteries (left & right)

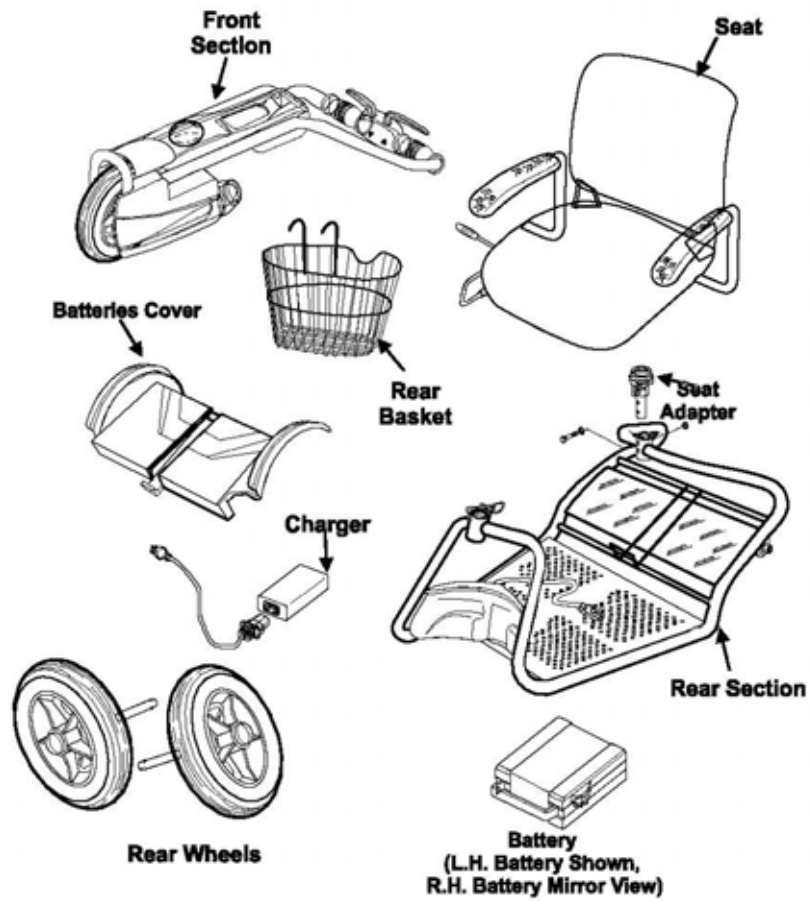

Figure 1.

## CHAPTER 2 - ASSEMBLY

2

### 2.1 Installation of Rear Wheels (See Fig. 2)

- a. Squeeze the center **Pin** in the **Hub Cap**. Push the wheel back on, to the end of the axle.

### **WARNING**

***After installing the wheel please check carefully that it is properly positioned and secured back in place.***

- b. To assure that the wheel is secured in its place, try to pull it off axle without touching the **Pins**. The wheel should **NOT** come off. If necessary repeat procedure a. above.

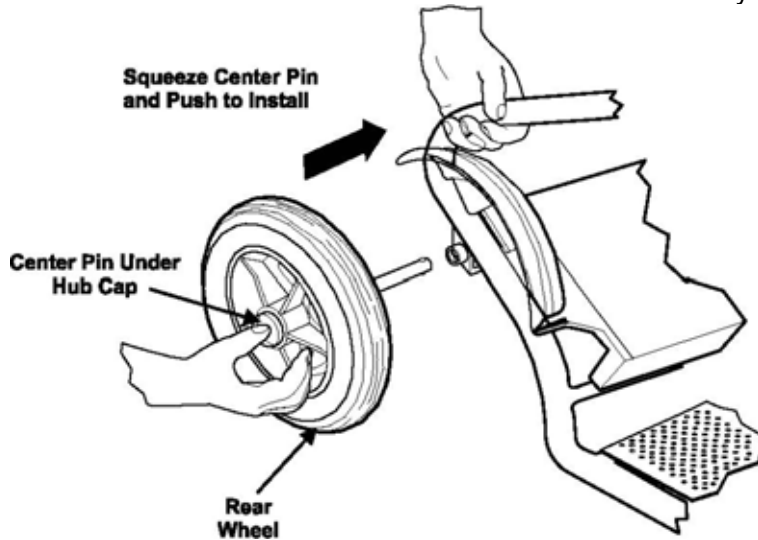

**Figure 2.**

## **2.2 Joining Tiller to Frame.**

- a. Place **Tiller** in front of the **Frame**. (See **Fig. 3**). Kneel at the left side of the **SUPERLIGHT** holding the left side of the **Top Handle Bars** of the **Tiller** with your left hand. The **Tiller** should be vertical and slightly inclined backward as shown in **Fig. 3**.

- b. With your right hand lift the **Housing** (at the front end of the **Frame**) and place it above the (black) **Tapered Pin** mounted on the **Tiller**.
- c. Let the **Housing** slide down onto the black **Tapered Pin** until you hear a “click”: at this time the **Retaining Spring** should engage the **Groove** on the **Tapered Pin** thus locking both sections to each other.

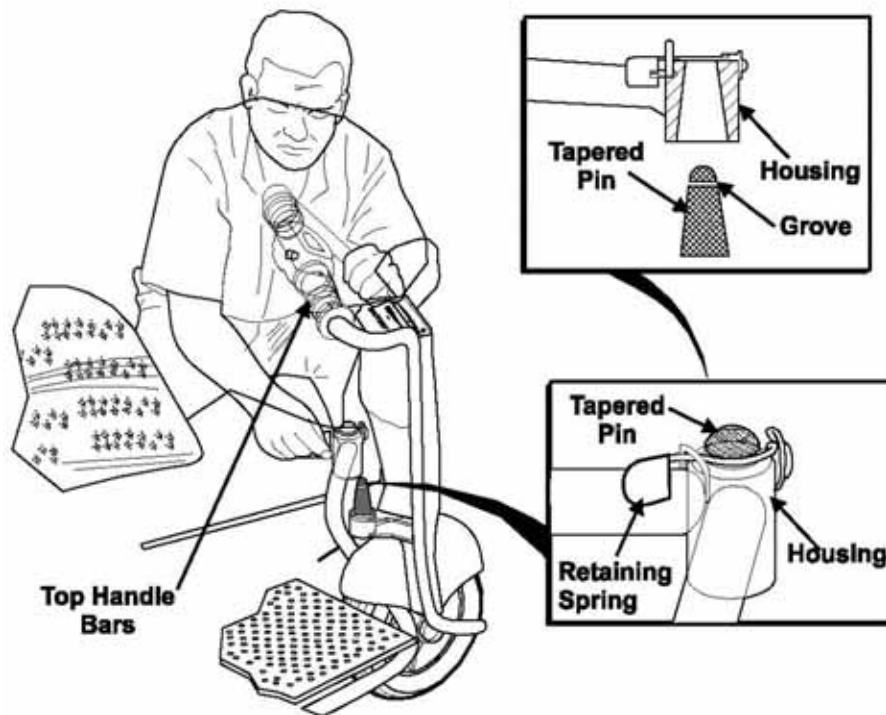

Figure 3.

6  
2.2 Joining Tiller to Frame. (Cont.)

- d. Connect the Electric Plug to the Socket in the Tiller (See Fig. 4).

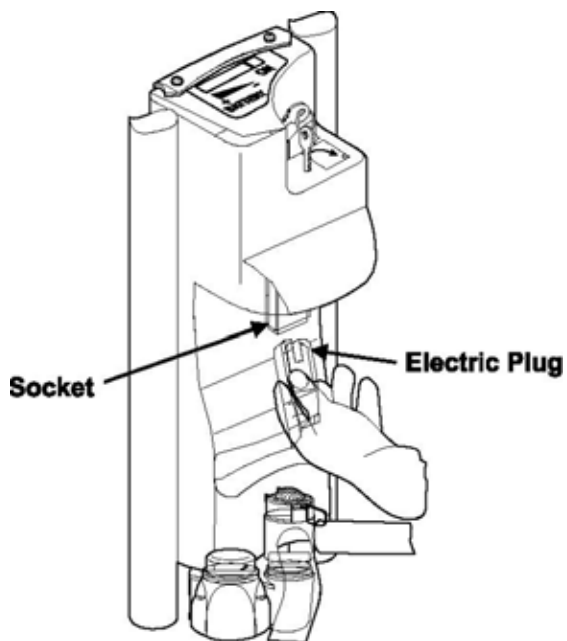

Figure 4.

7

### 2.3 Installation of Batteries (See Fig. 5)

*Note: Installation of L.H Battery is identical to R.H. Battery. L.H. Battery is shown.*

- a. Place battery in its location on the frame.
- b. Connect **Battery Plugs** to battery.

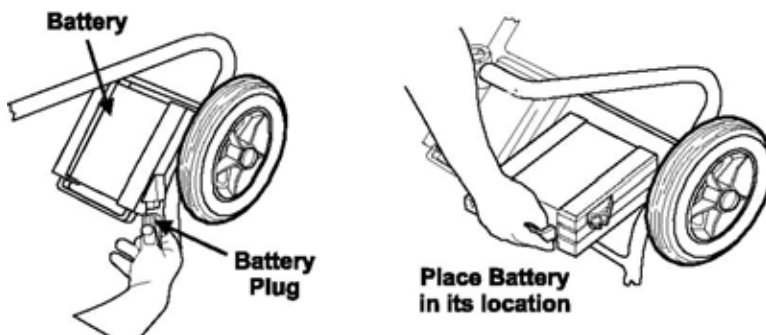

Figure 5.

8

### 2.4 Installation of Batteries Cover (See Fig. 6)

- a. Place **Batteries Cover** over the **Batteries**
- b. Push back **Plastic Clip** to secure the **Batteries Cover** in its location.

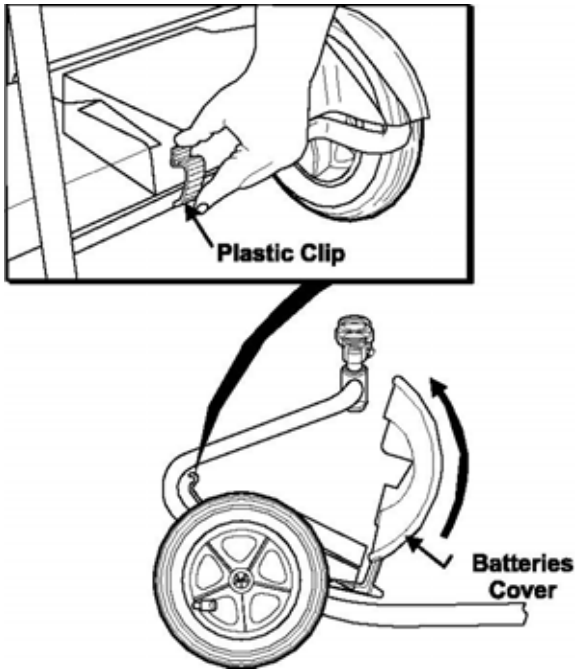

Figure 6.

## 2.5 Seat Installation (Figure 7)

### Seat Installation and Adjust:

a. Insert the **Seat Adapter** into the **Seat-Bushing**.

- (1) Verify that the **Seat-Bushing** slot is in forward direction.
- (2) Install bolt and washer and tighten the bolts very well, using the attached wrench.
- (3) Install and tighten the securing nut very well, using the attached wrench.
- (4) Install the **Seat** into the **Seat-Bushing** while the **Seat** is 45 degree to the side of the frame.
- (5) Press the **Seat Turning Lever** to place the **Seat** forward position.

b. Adjusting the height of the **Seat**. Remove nut, bolt and washer. Change the **Seat Adapter** height, install, bolt and washer and tighten strongly tightened and tighten the securing nut very well.

c. Install **Seat Upholstery**.

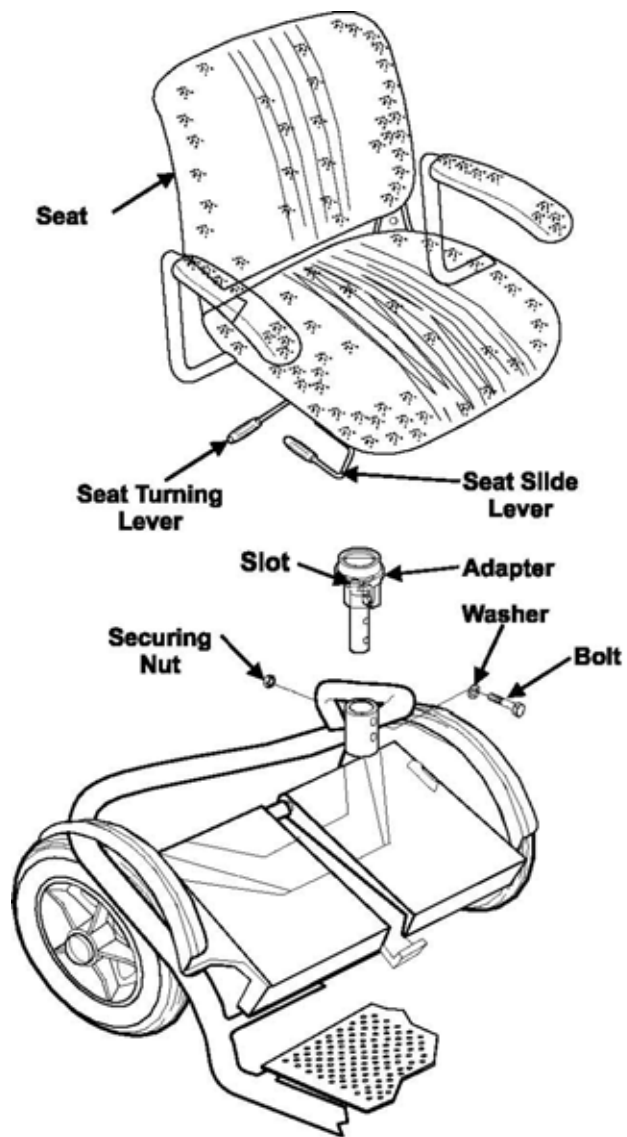

Figure 7.

## 2.6 Rear Basket Installation

- a. Install the Rear Basket by placing it on Support Rod welded to the rear frame. (See Fig. 8).

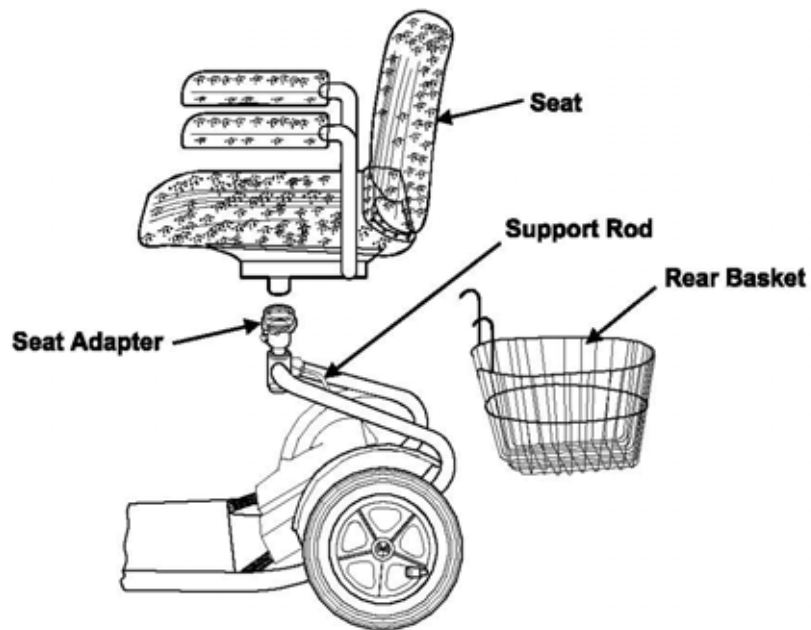

Figure 8.

13

### 2.4 After the assembly make sure that: -

- a. All parts are undamaged, properly assembled and secured.
- b. All electrical plugs are properly fastened.
- c. The operating levers return automatically to center position when they are squeezed and released.

It is recommended to charge the batteries overnight before operating the **SUPERLIGHT** for the first time. See Chapter 5 for charging instructions.

## **2.5 Seating into the SUPERLIGHT**

- a. For comfort entering into the **SUPERLIGHT (See Figure 9)**.
- b. Lift the **Seat Turning Lever** and turn the **Seat** 45 or 90 degree to the side of the frame.
- c. Sit down and turn swivel back towards the front of the vehicle while the lever is still pulled up.
- d. Use the **Seat Slider Lever** to adjust the **Seat** forward/Backward (**See Fig. 9**).
- e. Fold the **Seat Armrest** as desired while getting in or out of the vehicle.

**Note:** For your safety, always keep the armrest closed: **Forward – Down** while seated.

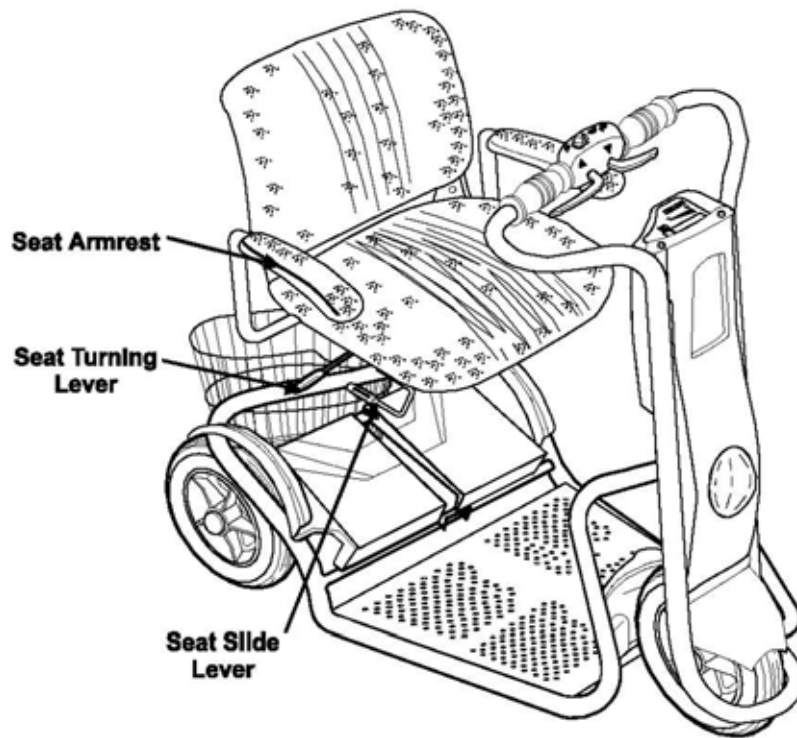

Figure 9.

16  
CHAPTER 3 -OPERATING INSTRUCTIONS

***PLEASE READ THOROUGHLY CHAPTER 8 - "SAFETY INSTRUCTIONS" - BEFORE DRIVING THE SUPERLIGHT.***

1. 3.1 Mount the **SUPERLIGHT**, insert the **Key** into the **Slot** and turn it clockwise to the (marked) **ON** position. The **Key** will remain in this position. **Panel On Light** should come ON. (See Fig. 10).

2. 3.2 You can drive forward by gently squeezing the **Right Hand Operating Lever**. You can drive **reverse** by gently squeezing the **Left Hand Operating Lever**.

- **The speed of the SUPERLIGHT is proportional to the deflection of the Levers; the more you squeeze the faster you go (either direction).**

3.3 **TO STOP : Release the Lever** - it returns automatically to its center (neutral) position and the **SUPERLIGHT** stops.

**Note:** For your safety and comfort the following features are part of the **normal** operating sequence;

- Slight delay after you squeeze the **Lever** before the motor is engaged-
- When squeezing or releasing the **Lever** you should hear a "click" indicating that the **Electromagnetic Brake** is activated.

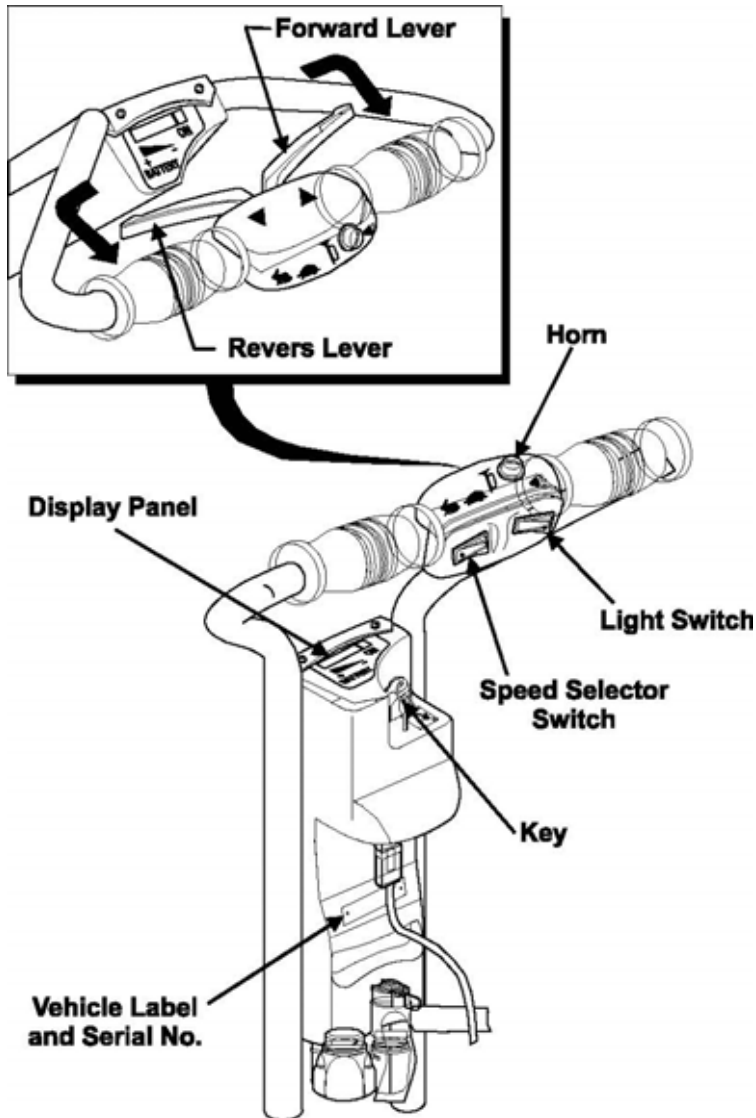

Figure 10.

3.4 The **SUPERLIGHT** has 2 speed modes ; **Low / High**

- .a. In the **High** speed mode (marked by the “hare” symbol next to the **Speed Selector** switch) the maximum attainable speed is 7.5 km/h (4.6 mph) When selector is in **High Speed Mode** – Green light of switch is ON. (**See Fig. 11**).
- .b. In the **Low** speed mode (marked by the “turtle” symbol next to the **Speed Selector** switch ) the maximum attainable speed is 4.5 km/h (2.8 mph).\*

- \* When selector is in **Low Speed Mode**
  - Green light of switch is OFF. (**See Fig. 11**).

**Notes:** 1. There is available a model of **SUPERLIGHT** in which the maximum speed is 6.0 km/h and the low speed is 3.0 km/h.  
2. The manufacturer to client's requirement can limit the speeds. Contact your dealer or our service center

#### **WARNING**

1. 1. ***Until you get used to the SUPERLIGHT and its operational features - Speed Selector switch should be set at the Low mode ("Turtle").***
2. 2. ***When going down hill always use the low speed mode.***

1. 3.5 Set the **Speed Selector** switch as desired.
2. 3.6 When "**extra-power**" is needed (i.e., climbing allowed slopes) use the **High** speed mode.

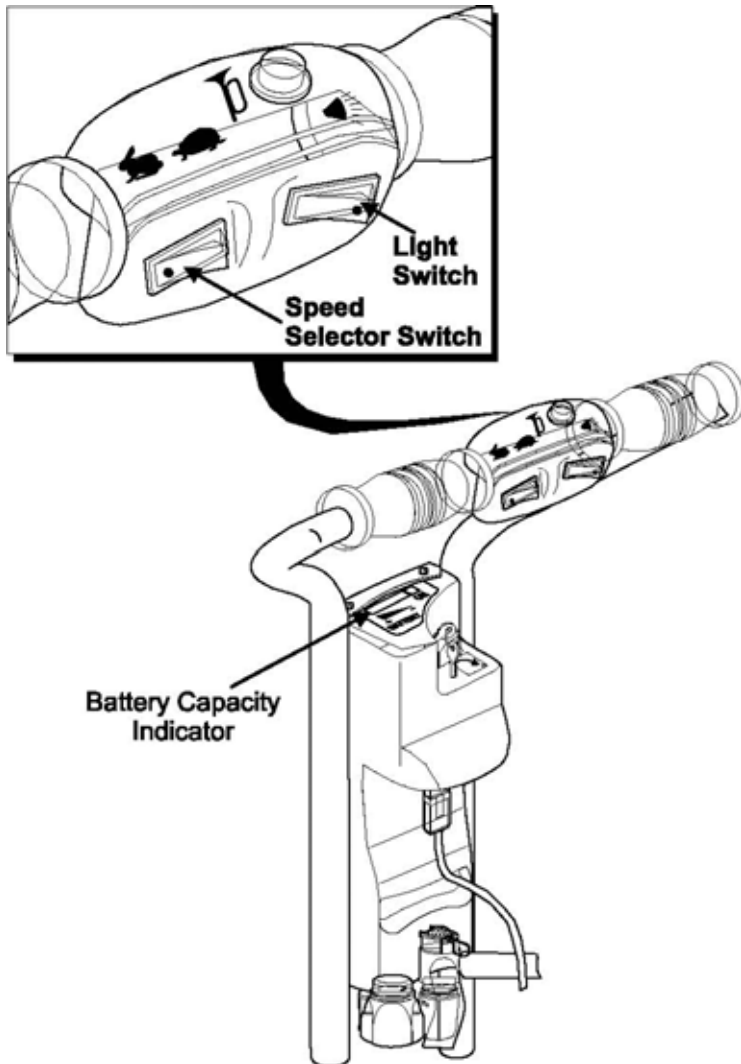

Figure 11.

### 3.7 Lights Operating (See Fig. 12)

To switch on the **SUPERLIGHT** light, use the Right-Blue switch . .

### 3.8 Battery Capacity Indicator (See Fig. 12)

The Battery Capacity Indicator is part of the Display Panel. The indicator contains 4 left leds .

The battery capacity is proportional to the numbers of the illuminated leds. (Not include the ON led).

Thus 4 Illuminated leds means: 75%-100% capacity. Thus 3 Illuminated leds means: 50%-75% capacity Thus 2 Illuminated leds means: 25%-50% capacity  
Thus 1 Illuminated leds means: 0%-25% capacity

**Notes:** 1. The **Battery Capacity Indicator** reset itself to full (4 leds) only after full recharge.

2. In case that **Charging Adapter** is used to charge the **Batteries** out of the **SUPERLIGHT**, the **Battery Capacity Indicator** of the vehicle will not reset automatically

To reset the **Battery Capacity Indicator** Turn on the key switch and wait for **2 minutes without driving**

**Note:** We recommend charging the batteries at the end of each day.

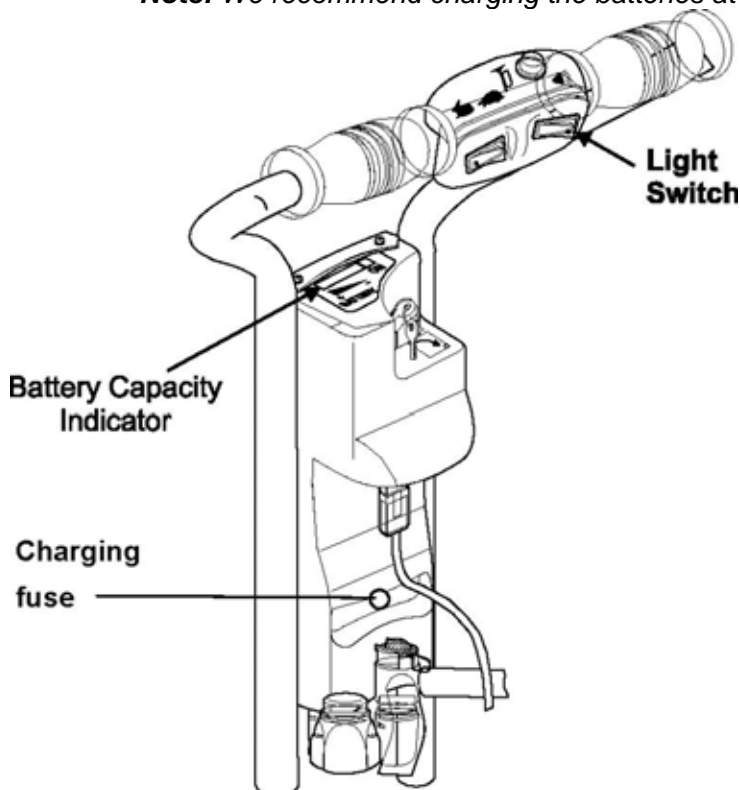

Figure 12.

3.9 In case of power fail, low battery or other fail

The **SUPERLIGHT** can be pushed manually by turning the **Motor Cap Knob** in clockwise (See Fig. 13) and pushing the **SUPERLIGHT** by hand.

The **SUPERLIGHT** will not operate and the buzzer will beep until the **Motor Cap Knob** is turned back to its original position.

(The buzzer will operate only when the key switch is in "ON" position).

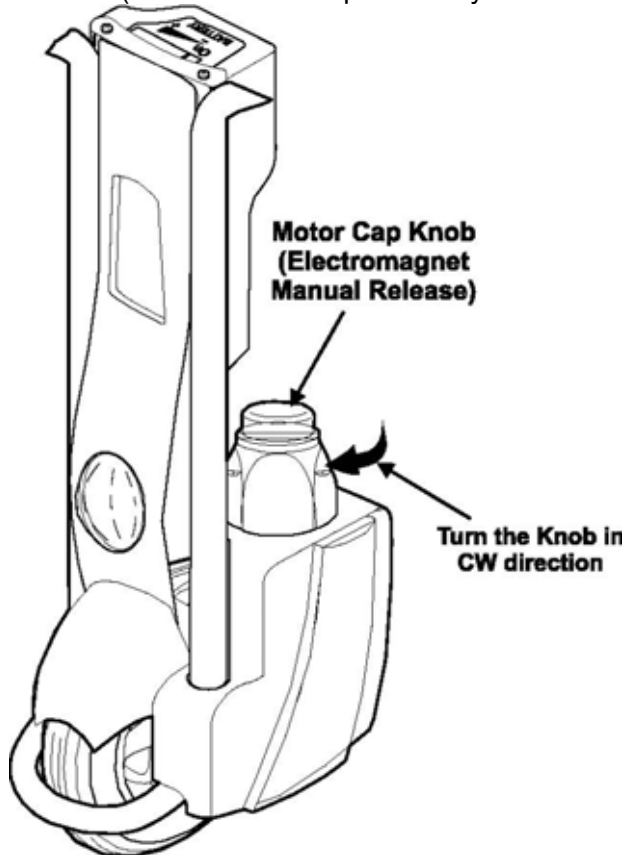

Figure 13.

## CHAPTER 4 -DISASSEMBLY

### 4.1 Separation of Tiller from Frame (See Fig. 14).

For ease of operation we recommend working on the left side of the **SUPERLIGHT** (facing forward ):

- .a. Disengage the **Electric Plug** from its socket in the **Tiller** by squeezing the **Snap Button** (located on the plug) - and pull.
- .b. Support the **Tiller** with your left hand holding the **Upper Left Rail**.
- .c. Push the **Retaining Spring** with the thumb of the right hand until it is freed from the **Groove** on the (black) **Tapered Pin**.
- .d. Carefully lift the **Frame** off the **Tapered Pin** and lay both sections on the floor.

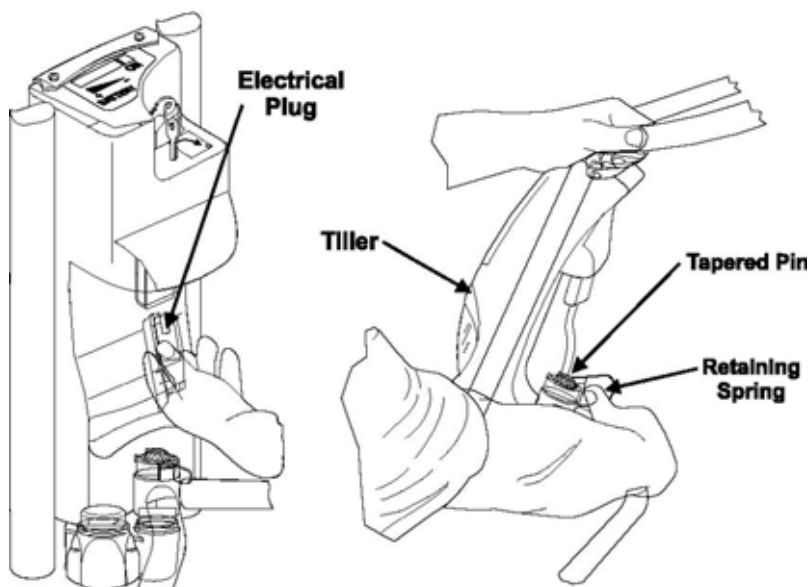

**Figure 14.**

26

#### **4.2 Removal of Seat (See Fig. 15)**

- .a. Remove the **Seat** from the **Seat Adapter** by lifting the **Seat** straight up while turning **Release Lever** is pulled only when the **Seat** is 45° back direction to the left.
- .b. Remove the **Rear Basket** by lifting it up from its **Support Rod**.

27

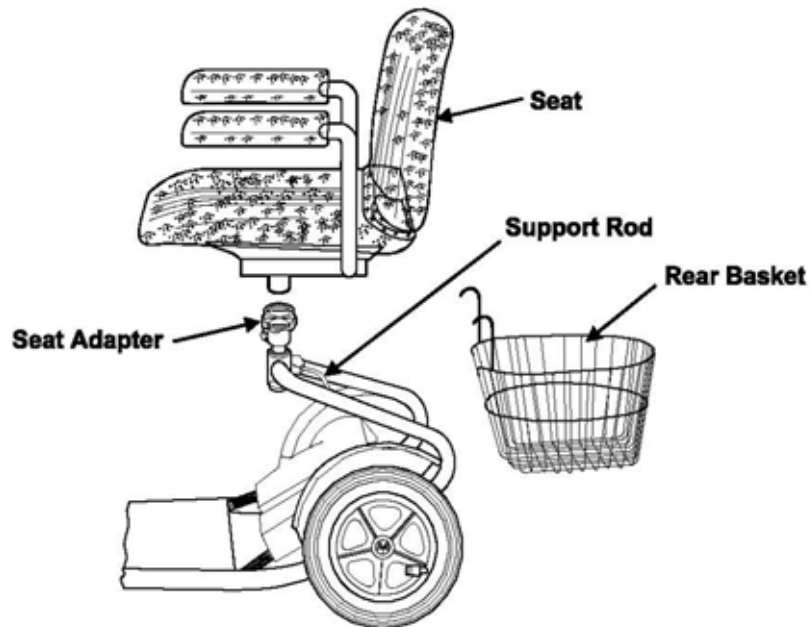

Figure 15.

### 4.3 Removal of Batteries

28

Batteries can be easily removed from your **SUPERLIGHT** as follows -

- .a. Remove **Seat** and **Rear Basket** (see instructions in paragraph 4.2 above).
- .b. Open **Batteries Cover** - (See Fig. 16).

1) Pull back **Plastic Clip**

2) Tilt and lift up **Cover** as shown

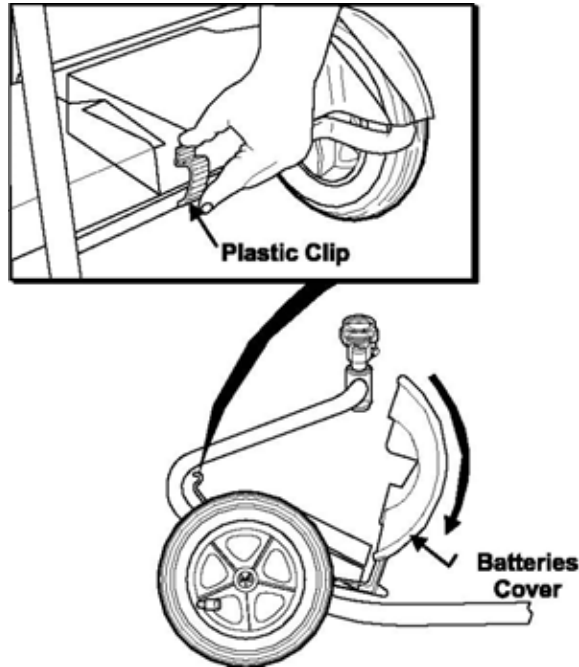

Figure 16.

- .c. Disconnect cables from batteries: unplug **Battery Plugs**.
- .d. Remove each battery BY PULLING **UP** THE HANDLE AND LIFTING THE BATTERY

29

(See Fig. 17).

**WARNING**

***Failure to follow above instructions could cause pinching of your hand or fingers if battery slides down and causes hand to come in contact with other parts.***

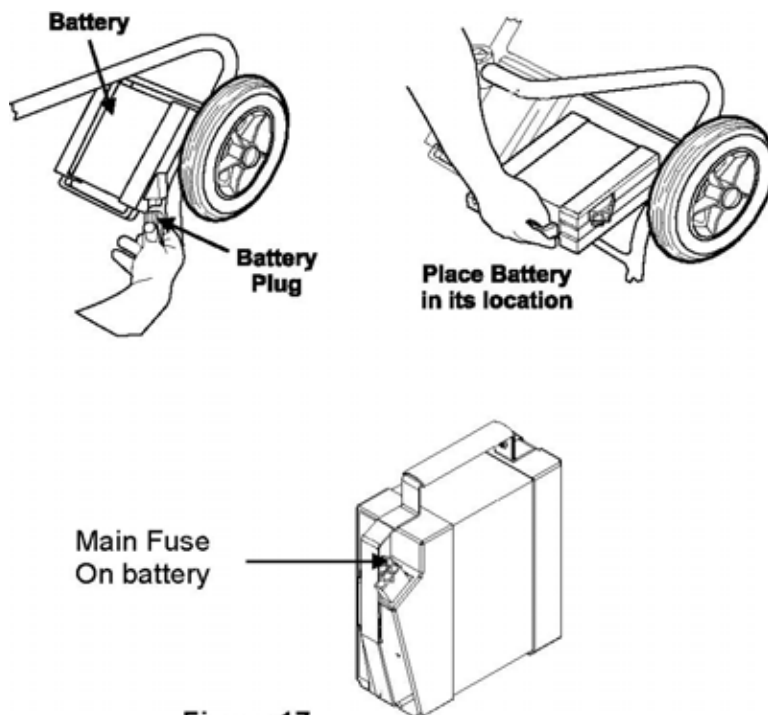

Figure 17.

#### 4.4 Removal and Installation of Rear Wheel/s (See Fig. 18)

**Rear Wheel/s** can be removed to facilitate storage at home, in the trunk of your car or for general service.

#### **WARNING**

*Before attempting to remove Rear Wheel/s, you need to support the SUPERLIGHT by inserting any support block under the Frame. The block should be large and strong enough to allow the wheel/s to clear the ground by approximately 3-4 cm (1.2-1.6 inch).*

#### **REMOVAL**

- a. Squeeze the center **Pin** in the **Hub Cap** and pull the wheel off the axle.

#### **INSTALLATION**

- b. Squeeze the center **Pin** in the **Hub Cap**. Push the wheel back on, to the end of the axle.

#### **WARNING**

*After installing the wheel please check carefully that it is properly positioned and secured back in place.*

- c. To assure that the wheel is secured in its place, try to pull it off axle without touching the **Pins**. The wheel should **NOT** come off. If necessary repeat procedure b. above.

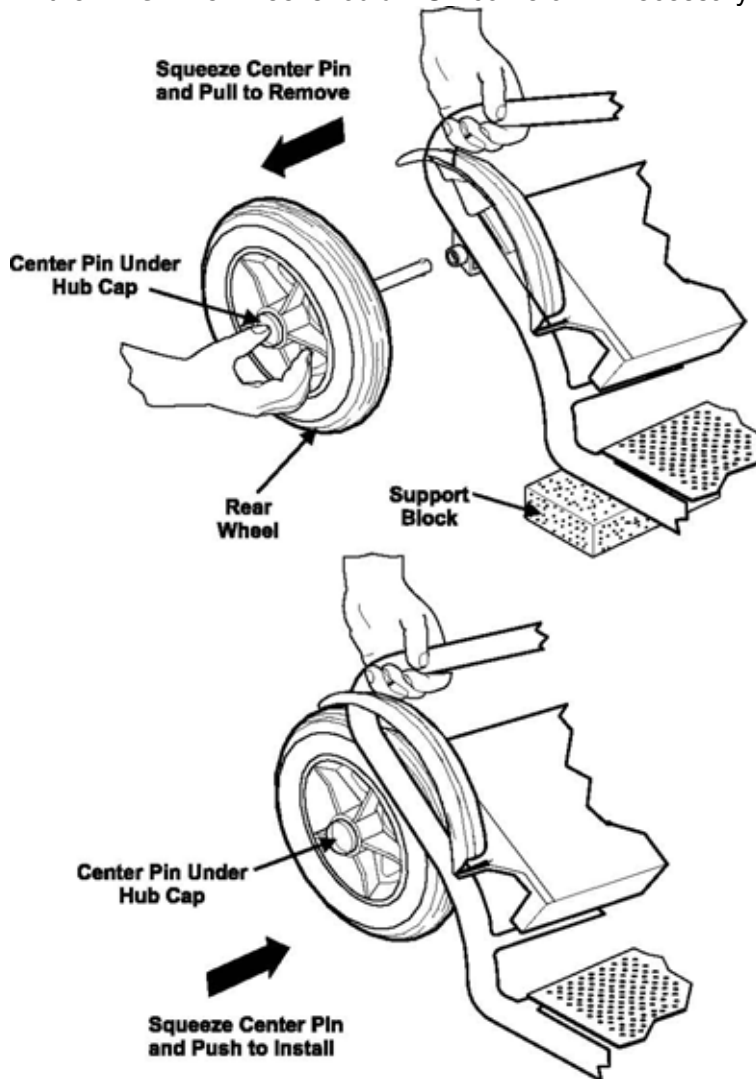

Figure 18.

## CHAPTER 5 - CHARGING BATTERIES

The **Battery Charger** supplied with your **SUPERLIGHT** controls the charging operation, prevents over-charging and prolongs the life of the batteries.

Read chargers instructions carefully before using the charger.

*Note: There is no ON/OFF power switch to the charger.*

### 5.1 Charging Batteries (See Fig. 19)

- .a. Insert the **Charging Plug** into the **Charging Socket** in the right hand side of the **Tiller** of the **SUPERLIGHT**.
- .b. Plug the power cord of the **Charger** into a wall outlet.
- .c. The **Charger Lamp** will show as follows: **Red** – Charger Cord is plugged into the wall outlet. **Yellow** – Charging **Green** – Battery are fully charged .

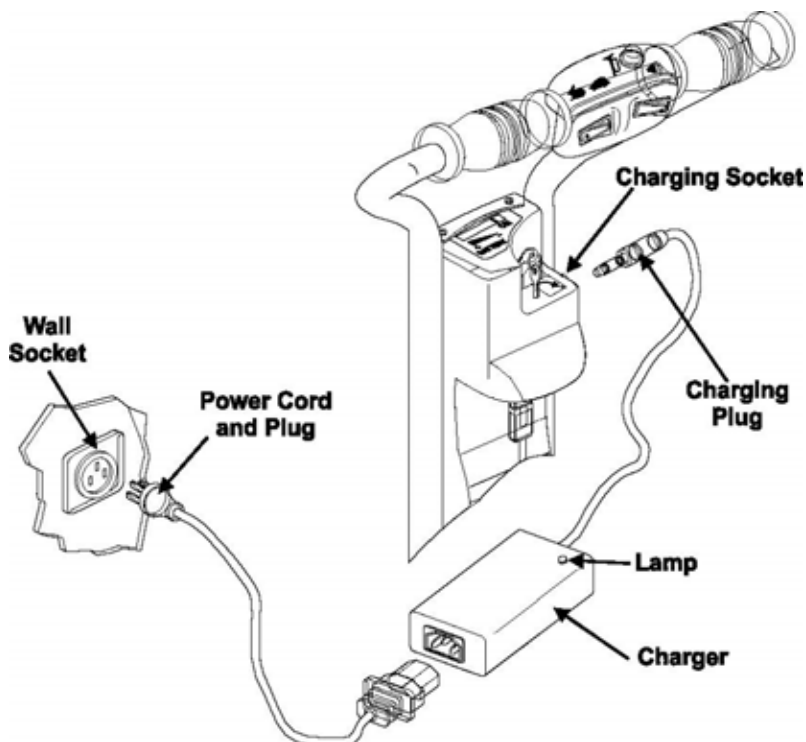

Figure 19.

When charging is complete and you are ready to go - unplug the **Charger** from the wall outlet and then pull out the charging plug from the charging socket.

- .d. Under ideal storage conditions, batteries which were charged to full capacity and not used - will remain charged for approximately 6 months.
- .e. If you are planning not to use your **SUPERLIGHT** for an extended period of time, we recommend charging it for two days and then disconnecting the batteries.
- .f. If you have not used your **SUPERLIGHT** for an extended period of time, charge the batteries for at least 12 hours before driving.

**Notes:** • *There is NO need to disconnect the **Charging Plug** promptly after the charging is complete.*

. • *HOWEVER, do not leave the **Charger** connected to the batteries for more than two weeks.*

. • *As long as the **Charging Plug** is in the **Charging Socket**, the electronic control of the **SUPERLIGHT** automatically cuts all power to the motor and the **SUPERLIGHT** can not be driven.*

## 5.2 Charging Adapter (Optional)

The **Charging Adapter** enables charging the batteries when they are removed from the **SUPERLIGHT**.

This is needed when a wall outlet is not available close to the **SUPERLIGHT's** position, when you have extra set of batteries, or when the **SUPERLIGHT** is stored . In such cases you can remove the batteries from the **SUPERLIGHT** (as per the instructions in Chapter 4) and use the **Charging Adapter** to charge the batteries.

- .a. Connect the two **Electrical Plugs** of the **Charging Adapter** to the two batteries.
- .b. Connect the **Charging Plug** of the **Charger** to the **Charging Socket** in the **Charging Adapter**.
- .c. Connect the **Charger** to a wall outlet.

– The charging process described in paragraph 5.1.

**Note:** *See relevant battery capacity indicator instructions (paragraph 3.8) when using charging adapter.*

**. In case that Charging Adapter is used to charge the Batteries out of the SUPERLIGHT, the Battery Capacity Indicator of the vehicle will not reset automatically**

**To reset the Battery Capacity Indicator Turn on the key switch and wait for 2 minutes without driving**

**CHAPTER 6 - STORING IN CAR****See Fig. 20**

The **SUPERLIGHT** design, its small dimensions and low weight allow for easy and simple storage and transportation in almost all types of cars.

1. 6.1 Take off the **Seat** and the **Rear Basket**.
2. 6.2 Separate the **Tiller** from the **Frame** following instructions in Chapter 4.

**WARNING**

***Never try to lift a fully assembled Frame by yourself as it is heavy and weights 26.0 Kg (57.2 lb.) without the Seat and the Rear Basket.***

- 6.3 You can store the **SUPERLIGHT** in a car AFTER disassembling the **Seat**, **Basket** and **Batteries**. If necessary take off also the **Rear Wheel/s** (refer to Chapter 4 for instructions).

**WARNING**

***The Frame as described in paragraph 6.3 weights only 10.6 Kg (23.3 lb.) However user should be aware of his capabilities and should refrain from attempting to lift this load if it exceeds whatever he is allowed to lift.***

1. 6.4 With the help of another person you can lift the complete **Frame** and place it in the trunk.
2. 6.5 In both cases (paragraph 6.3 and 6.4), store the **Tiller**, the **Seat** and the **Basket** on top or alongside the **Frame** - as space allows: take steps to assure that the sections and the parts do not rub against each other.

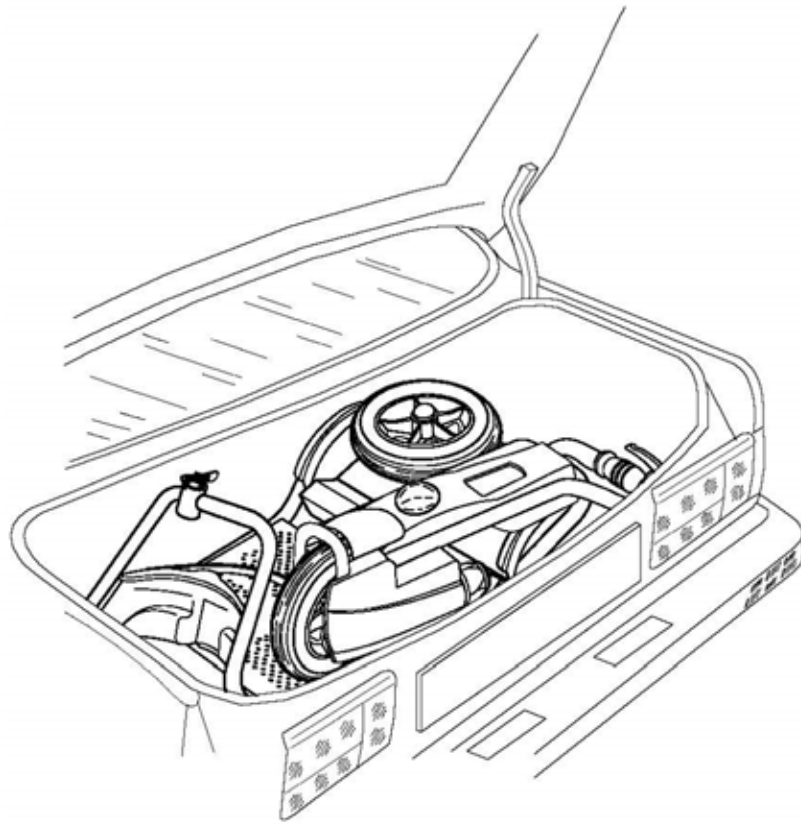

Figure 20.

38  
CHAPTER 7 -TROUBLESHOOTING

No.	Trouble	Probable Cause	Corrective Action
-----	---------	----------------	-------------------

1	Green Lamp not ON when Key is turned, Or the Green lamp is Flashing	- Cables not properly connected or need repair -Main fuse on battery assembly popped out or electrical failure - electronic system failure.	- Check cables and reinsert all connections. If the problem is not resolved call your dealer or Service Center -Reset the fuses See figure 17 (Maximum 2 times) - turn off – on the key - Call dealer or Service Center
2	Battery capacity Indicator show low capacity	- Batteries need recharging	- Recharge Batteries
3	When squeezing Operating Lever a “click” is not heard	-The Electro Magnetic Brake is out of order.	<b>-DO NOT DRIVE SUPERLIGHT</b> Call dealer or Service Center
4	When squeezing Operating Lever (either left or right) and releasing it the Lever does not return to the neutral position.	-The Lever (internal) Spring is broken or displaced	<b>-DO NOT DRIVE SUPERLIGHT</b> Call dealer or Service Center

### CHAPTER 7 -TROUBLESHOOTING (Cont.)

No.	Trouble	Probable Cause	Corrective Action
5	Drive is not smooth or drive is irregular.	- Batteries not charged, or - Batteries need replacement	-Charge Batteries; if problem not resolved:- - Replace Batteries. - Call dealer or Service Center
6	Buzzer beeps and vehicle does not move when squeezing operating lever.	- Manual release knob at top of motor cover is turned	- Turn back the motor knob - Call dealer or Service Center

### BATTERY CHARGER - TROUBLESHOOTING

No.	Trouble	Probable Cause	Corrective Action
1	Charger indicator is not ON while the charger is plugged into wall outlet	Faulty charger	Replace charger
2	Charger indicator does not change color to yellow or green when the charging plug is inserted into socket in tiller	Loose contact between plug and socket Charging fuse popped out	Pull plug and insert again. Reset the charging fuse on tiller (see fig. 12) If problem recurs call Service Center
3	Green light does not turn ON after more then 20 hours	Batteries not fully charged yet Old batteries Charger needs repair	Continue charging overnight If problem persists call Service Center Call Service Center
4	The Battery Indicator does not reset into full battery charge after full charging	Faulty charger The key switch was Turn off during charging	Replace charger Turn on the key switch for 2 minutes Without driving

## CHAPTER 8 -SAFETY INSTRUCTIONS

The **SUPERLIGHT** can be operated indoors, as well as outdoors on flat paved surfaces.

Please note and strictly adhere to the following Safety Instructions. Additional Warnings and Notices are printed in this USER'S MANUAL ; **it is imperative that you read carefully all chapters of this Manual before operating the SUPERLIGHT**. It is also advisable to refresh your memory by re-reading this Manual every few months or as applicable to user's memory.

1. 8.1 Get acquainted with the **SUPERLIGHT** and its operational features before driving it. Drive very slowly until you get used to the **SUPERLIGHT**, to its different functions and safety features, to its braking capabilities and limitations.
2. 8.2 Due to the low ground clearance, It is strictly forbidden to climb up or down any obstacle exceeding 6 cm (2.3").
3. 8.3 Watch carefully for pedestrians and drive your **SUPERLIGHT** accordingly.

In crowded area always drive with **Speed Selector** set on **Low** (turtle).

4. 8.4 Drive **ONLY** where permitted according to all applicable laws and ordinances.
5. 8.5 DO NOT turn the **Key** to the OFF position while in motion; this may cause abrupt and excessive deceleration which in turn may cause injury to user and damage to the **SUPERLIGHT**.
6. 8.6 The load in the rear basket should not exceed 10 kg ( 22 lb.).
7. 8.7 The **SUPERLIGHT** is designed and built to be carry ONE person only: Never operate it with an additional person or child on board.
8. 8.8 **CLEANING : Never use a hose** ; this may severely damage the power and electronic components.

Clean your **SUPERLIGHT** using only a damp cloth with mild detergent.

- 8.9 **Emergency Braking** in case of danger when driving forward, **Squeeze Reverse Lever** to stop. In case of danger when reversing - squeeze the **Forward Lever**. This may cause abrupt and excessive deceleration which in turn may cause injury to user and damage to the **SUPERLIGHT**.

### **WARNING**

***Persons with impaired capacity and/or untrained persons should not operate the SUPERLIGHT under any conditions. Special care must be exercised to prevent children from operating the SUPERLIGHT.***

- 8.10 **Emergency Moving.** In case of emergency cases, to move the vehicle when there is a fail on control or battery system:- Turn the **Motor Cap Knob** at the top of the motor in **CLOCKWISE** direction and push the **SUPERLIGHT by hand** forward or reverse as needed.

## **CHAPTER 9 -SERVICE**

Your **SUPERLIGHT** is designed and built to provide a long, useful and troublefree life. Occasionally it may require service depending on the conditions and environment to which it was exposed.

We recommend that for service and repair you maintain contact the authorized dealer where you purchased your **SUPERLIGHT**.

If this is not possible, please contact one of our Service Centers and we will either assist you over the telephone or provide you with the name and address of the nearest authorized service where you can receive immediate assistance.

The **SUPERLIGHT** needs little periodical service, but when it does it should be carefully performed at specified times to avoid risk of failure and to insure continuous and smooth operation.

When servicing the **SUPERLIGHT**, park it on level surface and keep the key

disengaged.

### Periodical servicing requirements

No.	Service	Frequency
1	Check tires for damage and replace if necessary.	Every two Month
2*	General check of screws tightening.	Every half year
3*	Inspection of electromagnetic brake	Every half year
4*	Inspection of the wheel bearing for excessive wear	Every half year
5	Cleaning	As required

\* Those technical operations for the vehicle should be done only by a trained and authorized technician.

#### 9.1 Tires and air pressure inspection

As standard, the **SUPERLIGHT** is supplied with PU (Polyurethane) tires which does not need any service.

In case of using air tires: -

- .a. Normal air pressure in the **SUPERLIGHT** tires is essential for retaining the vehicle's travel ability and stabilization.
- .b. The tires should be inspected for external completeness and general condition, and for proper seating of the tire on the entire wheel perimeter.
- .c. The air pressure of the tires should be inspected every two weeks, especially after a long storage time period.
- .d. Normal tire air pressure - 36 psi (2.4 bars).
- .e. Air pressure may be replenished or inspected in gas stations or by a foot/hand pump equipped with pressure gage.

#### 9.2 Cleaning

**NOTE:** The **SUPERLIGHT** should be cleaned with water and soap only. Do not clean the vehicle with a water jet stream.

- .a. Clean the external assemblies only.
- .b. Upon completion of the cleaning, wait for parts to dry.

CHAPTER 10 -SPECIFICATIONS	Metric (cm)	U.S. (inches)
* DIMENSIONS:		
Width	62	24.4

Length with straight handlebars	115	45.3
Height of seat from floor	55-60	21.5-23.6
Ground clearance	7.5	3.0
<b>WEIGHTS :</b>	<b>Metric (kg)</b>	<b>U.S. (lb.)</b>
Tiller	10.3	22.6
Frame - complete	36.5	80.3
Frame (without: wheels, batteries, seat, basket)	10.6	23.3
Batteries (each)	6.8	15.0
Wheel (each)	0.9	2.0
Seat	9.9	21.7
<b>OPERATIONAL CHARACTERISTICS:</b>	<b>Metric</b>	<b>U.S.</b>
Speed (Speed Selector switch)		
Forward HIGH up to	7.5 km/h	4.7 mph
Forward LOW up to	4.5 km/h	2.8 mph
Reverse up to	4.5 km/h	2.8 mph
Maximum allowed load	110 kg	240 lbs.
Maximum rear basket load	10 kg	22 lbs.
Maximum traveling distance with fully charged batteries (user weight 75 kg, level surface, high speed)	20 km	12.5 miles
Maximum downhill slope allowed	13 %	7.4 deg.
Maximum uphill climb (slope) allowed	13 %	7.4 deg.
Turning radius	70 cm	27.5 inch
Minimum safe turning radius	80 cm	31.5 inch
<b>OPERATIONAL CHARACTERISTICS:</b>	<b>Metric</b>	<b>U.S.</b>

**(Cont.)**

Maximum allowed side angle 13 %

7.4 deg.

**WHEELS & MARKINGS ON TIRES:**

Front - Solid,  $\phi$ 250 mm x 50 mm Rear - Solid,  $\phi$ 250mm x 50mm, MAX. , quick release

**GENERAL:**

Drive

Front wheel

Motor/Gear	Direct drive
Batteries	2 x 18 Ah, 12V
Controls	As per ISO 7176.
Braking	Automatic /Electromagnetic Braking + Manual Release
EMI immunity level	20 V/m

#### **CHARGER:**

Output Input Fuse Charging time for empty batteries 1.5 Amperes, 24 Volts 85 V to 250 V AC As marked on charger label 10-12 hours

#### **OPTIONS:**

- . • Front Basket
- . • Charging Adapter
- . • Left seat
- . • Charger form cigarette lighter socket of car

\* All specifications are subject to change without notice

### **CHAPTER 11 -EMI WARNING**

All types of electrically powered vehicles, such as powered wheelchairs and motorized scooters (**in this text all types will be referred to as “powered vehicles”**) may be susceptible to electromagnetic interference (EMI), which is interfering **electromagnetic energy (EM)** emitted from sources such as radio stations, TV stations, amateur radio (HAM) transmitters, two way radios and cellular phones. The interference (from radio wave sources) can cause the powered vehicle to release its brakes, move by itself, or move in unintended direction. It can also damage the powered vehicle’s control system. The intensity of the interfering EM energy can be measured in volts per meter (V/m). Each powered vehicle can resist EMI up to a certain intensity. This is called its “immunity level”. The higher the immunity level, the greater the protection. At this time, current technology is capable of achieving at least 20 V/m immunity level, which would provide useful protection from the more common sources of radiated EMI. This **SUPERLIGHT** as shipped with no further modification, has an immunity level of 20 V/m.

There are a number of sources of relatively intense electromagnetic fields in everyday environment. Some of this sources are obvious and easy to avoid. Others are not apparent and exposure is unavoidable. However, we believe that by following the warning listed below, your risk of EMI will be minimized.

The sources of radiated EMI can be broadly classified into three types:

- 1) **Hand held portable transceivers** (transmittersreceivers) with the antenna mounted directly on the transmitting unit. Examples include: citizen band (CB) radios, “walkie talkies”, security, fire and police transceivers, cellular telephones and other personal communication devices. \*\* NOTE: some cellular telephones and similar devices transmit signals while they are ON, even when not being used.
- 2) **Medium range mobile transceivers**

Such as those used in police cars, fire trucks, ambulances and taxis. These usually have the antenna mounted on the outside of the vehicle, and -

3) **Long-range transmitters and transceivers such as commercial broadcast transmitters** (Radio and TV broadcast antenna towers) and amateur (HAM) radios.

NOTE: Other types of hand held devices, such as cordless phones, laptop computers, AM/FM radios, TV sets, CD players, cassette players and small appliances such as electric shavers and hair dryers, as far as we know, are not likely to cause EMI problems to your powered vehicle.

### **Powered Vehicle Electromagnetic Interference (EMI)**

Because EM energy rapidly becomes more intense as one moves closer to the transmitting antenna, the EM field from hand-held radio wave sources (transceivers) are of special concern. It is possible to unintentionally bring high levels of EM energy close to the powered vehicle's control system while using these devices. This can affect powered vehicle movement and braking. Therefore, the warnings listed below are recommended to prevent possible interference with the control system of the powered vehicle.

**WARNINGS** : Electromagnetic interference (EMI) from sources such as radio and TV stations, amateur radio (HAM) transmitters, two-way radios and cellular phones can affect powered vehicles.

Following the warnings listed below should reduce the chance of unintended brake release or powered vehicle **movement which could result in serious injury**:

- 1) Do not operate hand-held transceivers (transmitters/receivers) such as citizen band (CB) radios, or turn ON personal communication devices such as cellular phones, while the powered vehicle is turned ON ;
- 2) Be aware of nearby transmitters, such as radio or TV stations and try to avoid coming close to them
- 3) In unintended movement or brake release occurrences turn the powered vehicle OFF **as soon as it is safe**.
- 4) Be aware that adding accessories or components, or modifying the powered vehicle, may make it more susceptible to EMI (Note: there is no easy way to evaluate their effect on the overall immunity level of the powered vehicle), and -
- 5) Report to us all incidents of unintended movement or brake release and note whether there is a source of EMI nearby.

### **Important information**

- 1) 20 volts per meter (V/m) is a generally achievable and useful immunity level against EMI (as of May 1994). The higher the level the greater the protection;

2) 2) This product as delivered to you has an immunity level of 20 V/m.



Produce by:

51

**AFIKIM ELECTRIC VEHICLES**

***KIBBUTZ AFIKIM 15148, ISRAEL TEL: 972-4-6754814, FAX: 972-4-6751456 e-mail:  
mainbox@afiscooters.com websites: [www.afiscooters.com](http://www.afiscooters.com)***

EDITION: 03 MODEL: SL-2 DATE: February 6, 2001

**Cat. No. -- PR00070**

Q:\SUPERLIGHT SL-2\word files\manual user sl-2\PR00070c - user manual - wheelcare.DOC